

2016 2500/3500





**ONE TOOL IS
DESIGNED TO
MASTER EVERY
JOB OUT THERE.**



THIS TRUCK



Properly secure all cargo.

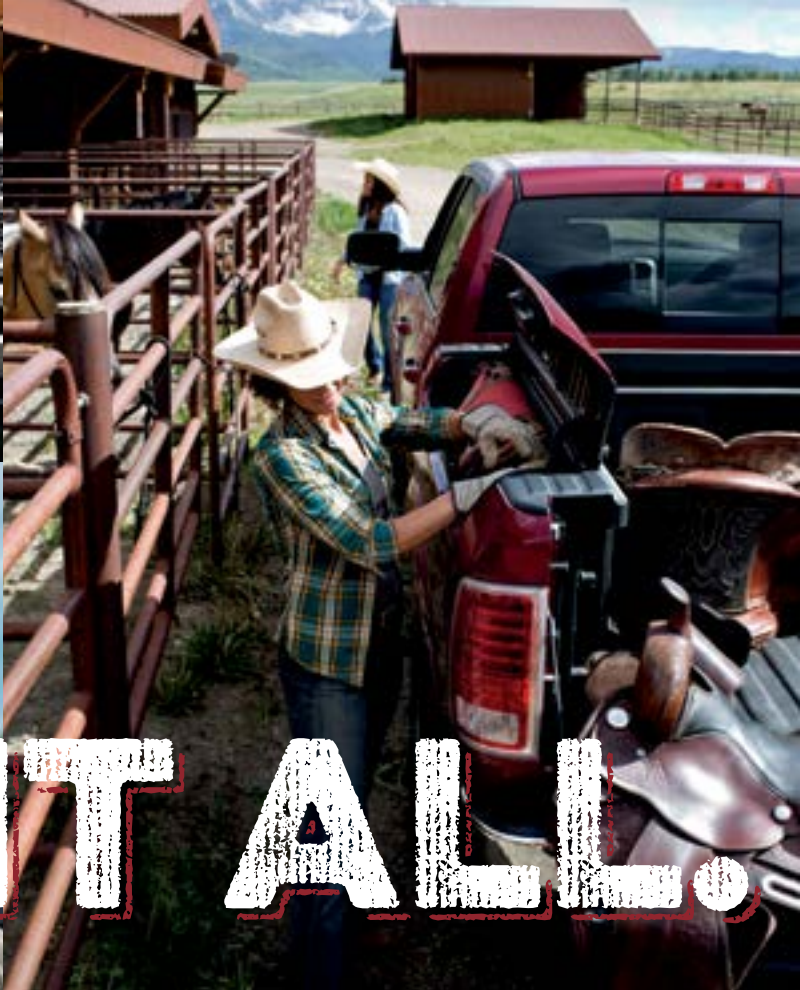

DOES IT ALL.



Properly secure all cargo.

JOB-RATED CAPABILITY.



FROM HEAD TO TOE,
IT'S MADE TO TOW.



By design, these trucks are born and bred to pull and haul. Huge available 7 x 11-inch trailer-towing mirrors with a power-folding feature make your Ram Heavy Duty a command and control center for towing.



Go—and tow—in the know: the full-color high-resolution screens in select Ram models feature dozens of graphics, conveying real-time data on virtually every mechanical function.



Available frame-mounted Mopar® Gooseneck Hitch Assembly with easy ball removal for fast flatbed conversion. Optional Fifth-Wheel/Gooseneck Prep Package includes in-bed 7-pin connector. (Ball not included in Packages.)



Available Mopar Fifth-Wheel Hitch enables super-tough trailer towing with authority. Options include a hitch with sliding rails or one that mounts directly into the optional Fifth-Wheel/Gooseneck Prep Package mounts, saving time and effort.



HOW RAM VIEWS TOWING.

There's no looking back...to the old days, that is. Only Ram Heavy Duty offers an available, class-exclusive^[1] Cargo-View Camera^[2] for an invaluable on-screen display of the cargo bed—ideal for gooseneck or fifth-wheel hookups. Add the available ParkView® Rear Back-Up Camera^[3] to ease conventional trailer hookups—plus the capability to toggle between the two views on the 8.4-inch touchscreen—and you're looking at exceptional towing convenience.



**31,210-LB
MAX
TOWING^[1]**

Ram 3500 with available Cummins® High Output Turbo Diesel



**7,390-LB
MAX
PAYLOAD^[1]**

Ram 3500 with 6.4L HEMI® V8



**900 LB-FT
MAX
TORQUE^[1]**

Ram 3500 with available Cummins High Output Turbo Diesel

*A note about this brochure: all disclaimers and disclosures can be found on the last page. ^[1]When properly equipped. Properly secure all cargo.

RAM 2500/3500 TOWING CAPABILITY

2500 TOWING SPECS

Maximum loaded trailer weights (when properly equipped)

				2500 — SAE J2807 STANDARD COMPLIANT							
				Regular Cab		Crew Cab				Mega Cab®	
				8' BOX		6'4" BOX		8' BOX		6'4" BOX	
				4x2	4x4	4x2	4x4	4x2	4x4	4x2	4x4
Automatic Transmission	POWERTRAIN	Axle Ratio	GCWR								
	5.7L HEMI® V8 CNG/66RFE 6-speed	3.73	15,000	12,520	9,980			9,190	6,960		
	5.7L HEMI V8/66RFE 6-speed	3.73	18,300	11,890	11,510	11,520	11,200	11,390	11,030	11,040	10,780
		4.10	20,300	13,890	13,510	13,520	13,190	13,390	13,020	13,040	12,780
	6.4L HEMI V8/66RFE 6-speed	3.73	19,800	13,320	12,930	12,940	12,630	12,810	12,460	12,520	12,240
		4.10	17,500				10,030				
4.10	22,800	16,320	15,930	15,940	15,630	15,810	15,460	15,520	15,240		
6.7L Cummins® Turbo Diesel I-6/68RFE 6-speed	3.42	25,300	17,980	17,540	17,510	17,210	17,370	17,030	17,170	15,540	
MT	6.7L Cummins Turbo Diesel I-6/ G56 6-speed	3.42	24,300	16,890	16,450	16,450	16,140	16,300	15,960	16,100	14,870

3500 TOWING SPECS

Maximum loaded trailer weights (when properly equipped)

				3500 — SAE J2807 STANDARD COMPLIANT													
				Regular Cab				Crew Cab				Mega Cab®					
				8' BOX		8' BOX DRW		6'4" BOX		8' BOX		8' BOX DRW		6'4" BOX		6'4" BOX DRW	
				4x2	4x4	4x2	4x4	4x2	4x4	4x2	4x4	4x2	4x4	4x2	4x4	4x2	4x4
Automatic Transmission	POWERTRAIN	Axle Ratio	GCWR														
	5.7L HEMI® V8/66RFE 6-speed	3.73	18,400	11,910	11,560			11,520	11,200	11,410	11,020			11,270	10,990		
		4.10	20,400	13,910	13,560			13,520	13,200	13,410	13,020			13,270	12,990		
	6.4L HEMI V8/66RFE 6-speed	3.73	19,900	13,370	12,970	13,020	12,640	12,970	12,640	12,830	12,470	12,450	12,100	12,710	12,400	12,210	12,020
		4.10	22,900	16,370	15,970			15,970	15,640	15,830	15,470			15,710	15,400		
	4.10	23,400				16,520	16,140					15,950	15,600			15,710	15,520
		3.42	25,300	17,910	17,560	17,550	17,180	17,490	17,200	17,360	17,010	17,000	16,660	17,160	16,800	16,770	16,460
	6.7L Cummins® Turbo Diesel I-6/68RFE 6-speed	3.73	27,300			19,550	19,180					19,000	18,660			18,770	18,460
		4.10	30,300			22,550	22,180					22,000	21,660			21,770	21,460
	6.7L Cummins High Output Turbo Diesel I-6/ AISIN® 6-speed	3.42	25,300	17,770	17,420			17,350	17,050	17,210	16,860			17,020	16,660		
3.42		29,300			21,410	21,030					20,860	20,510			20,620	20,320	
3.73		33,800			25,910	25,530					25,360	25,010			25,120	24,820	
4.10		39,100			31,210	30,830					30,660	30,310			30,420	30,120	
MT	6.7L Cummins Turbo Diesel I-6/ G56 6-speed	3.42	24,300	16,870	16,520	16,510	16,130	16,450	16,160	16,320	15,960	15,960	15,610	16,120	15,760	15,720	15,420
	3.73	26,300			18,510	18,130					17,960	17,610			17,720	17,420	

MT = Manual Transmission | DRW = Dual Rear Wheel | Weights given in lb. | Numbers in **Black boxes** reflect max ratings.

1. Payload and Max Trailer Weights are ESTIMATED values and rounded to the nearest 10 lb.
2. Payload = GVWR - Base Weight.
3. Payload and Trailer Weight Rating are mutually exclusive.
4. GAWRs, GVWRs and GCWRs should never be exceeded.
5. Trailer Weight Rating and Tow Vehicle Trailing Weight are calculated as specified in SAE J2807. Passenger Weight = 300 lb. Options Weight = 100 lb. Trailing Equipment Weight: 75 lb for conventional hitch, 70 lb for gooseneck and 250 lb for 5th-wheel. Tongue weight: 10 percent of the gross trailer weight for conventional hitch, 15 percent of the gross trailer weight for a 5th-wheel or gooseneck hitch. Payload and GAWR should never be exceeded and must account for all of the above weights, including the appropriate trailering equipment and tongue weight. Box-Off Body Completion Weight = 80 lb per foot from end of cab to end of frame.
6. The maximum tongue weight for Class V (hitch receiver) is limited to 1,800 lb.
7. A 5th-wheel or gooseneck hitch is required for trailers over 18,000 lb.
8. 13,800 lb. GVW stated for Regular Cab, 4x2, 6.4L V8 with 4.10 axle ratio applies to Tradesman® and ST packages only. All other price classes for this configuration (Regular Cab, 4x2, 6.4L V8 with 4.10 axle ratio) is 13,700 lb.

RAM 2500/3500 PAYLOAD CAPABILITY

2500 PAYLOAD SPECS

Maximum payload capacities (when properly equipped)

			2500							
			Regular Cab		Crew Cab				Mega Cab®	
			8' BOX		6'4" BOX		8' BOX		6'4" BOX	
			4x2	4x4	4x2	4x4	4x2	4x4	4x2	4x4
Automatic Transmission	POWERTRAIN	GVWR								
	5.7L HEMI® V8 CNG/66RFE 6-speed	9,200	2,350	1,970			1,850	1,630		
	5.7L HEMI V8/66RFE 6-speed	9,000	3,060	2,680	2,690	2,370	2,560	2,200	2,210	1,960
	6.4L HEMI V8/66RFE 6-speed	8,510 10,000	3,990	3,600	3,610	3,300	3,480	3,130	3,190	2,910
MT	6.7L Cummins® Turbo Diesel I-6/68RFE 6-speed	10,000	3,160	2,720	2,690	2,380	2,540	2,200	2,340	2,030
	6.7L Cummins Turbo Diesel I-6/G56 6-speed	10,000	3,060	2,630	2,630	2,310	2,470	2,130	2,280	1,960

3500 PAYLOAD SPECS

Maximum payload capacities (when properly equipped)

			3500													
			Regular Cab				Crew Cab				Mega Cab®					
			8' BOX		8' BOX DRW		6'4" BOX		8' BOX		8' BOX DRW		6'4" BOX		6'4" BOX DRW	
			4x2	4x4	4x2	4x4	4x2	4x4	4x2	4x4	4x2	4x4	4x2	4x4	4x2	4x4
Automatic Transmission	POWERTRAIN	GVWR														
		10,100	4,080													
	5.7L HEMI® V8/66RFE 6-speed	10,300		3,930												
		10,500				4,090										
		10,700					3,970									
		11,000						4,480					4,340			
		11,300							4,390					4,360		
		11,500														
	6.4L HEMI V8/66RFE 6-speed	10,200	4,140													
		10,400		3,940												
		10,500				4,040										
		10,800					4,010									
		11,100						4,500								
		11,200											4,480			
		11,400							4,440					4,370		
		13,300			6,890	6,510					6,320	5,970			6,080	5,890
		13,700			7,290	6,910										
		13,800			7,390											
	6.7L Cummins® Turbo Diesel I-6/68RFE 6-speed	13,900														6,680
		14,000									7,020	6,670				6,590
		11,100	4,180													
		11,500		4,230		4,160										
		11,600												3,930		
		11,700					4,070									
		12,000						4,530								
		12,300							4,480							
	6.7L Cummins High Output Turbo Diesel I-6/ AISIN® 6-speed	12,400												4,270		
		14,000			6,720	6,350					6,170	5,830			5,940	5,630
11,100		4,040														
11,500			4,090		4,020											
11,600													3,790			
11,700						3,920										
12,000							4,380									
12,300								4,330								
MT	6.7L Cummins Turbo Diesel I-6/G56 6-speed	12,400											4,130			
		14,000			6,580	6,200				6,030	5,680			5,790	5,490	
		11,100	4,140													
		11,500		4,190		4,120										
		11,600											3,890			
		11,700					4,030									
		12,000						4,490								
12,300							4,430									
12,400												4,230				
14,000				6,680	6,300					6,130	5,780			5,890	5,590	

MT = Manual Transmission | DRW = Dual Rear Wheel | Weights given in lb. | Numbers in **Black boxes** reflect max ratings.

1. Weights are estimated values rounded to the nearest 10 lb.
2. Payload = GVWR minus Base Weight.
3. Payload and Trailer Weight Rating are mutually exclusive.
4. GAWRs, GVWRs and GCWRs should never be exceeded.
5. 3500 Regular Cab, 4x2, 6.4L V8 with 4.10 axle ratio, GVWR of 13,800 lb applies to Tradesman® package only. All other price classes for this configuration (Regular Cab, 4x2, 6.4L V8 with 4.10 axle ratio), GVWR is 13,700 lb.

ONLY RAM HEAVY DUTY OFFERS THE MOST GAS-POWERED V8 ENGINE OPTIONS.[†]

A LEGEND

**5.7L HEMI® V8 • 383 HP
400 LB-FT OF TORQUE**



+ Competitive fuel efficiency, accompanied by performance and capability measured in tens of thousands of miles. When compared to other V8 engines in the class, the 5.7-liter HEMI V8 in single-rear-wheel Ram Heavy Duty models delivers incredible standard power and torque.

+ iDFO (interactive Deceleration Fuel Shut-Off) turns off the flow of fuel during deceleration, with no noticeable changes in operation, helping enhance fuel efficiency.

+ You expect this powerhouse to do the job. Heavy-duty cooling is standard on all HEMI V8 engines.

A BRUTE

**6.4L HEMI V8 • 410 HP
429 LB-FT OF TORQUE**



+ **Best-in-class[‡] gas horsepower** from the 6.4-liter HEMI V8: 410 working horses give you the ideal gas engine for acceleration and highway merging and cruising, even under the heaviest loads.

+ **Best-in-class[‡] gas towing** with the 6.4-liter HEMI V8 gives Ram Heavy Duty unrivaled authority—up to 16,320 lb on 2500 models, and up to 16,520 lb on Ram 3500 DRW models. (All towing figures apply to properly equipped trucks.)

+ Along with that **best-in-class[‡] gas horsepower** is **best-in-class[‡] gas torque**; the 6.4-liter HEMI V8 torque levels are rated at a super-competent 429 lb-ft @ 4,000 rpm.

+ The 6.4-liter HEMI V8 offers the advanced technology of Individual Cylinder Fuel Control, a diagnostic monitoring system that enables air/fuel refinements and ensures ideal mixtures for each individual cylinder.

+ The cooled Exhaust Gas Recirculation (EGR) System is **unique for a gas engine**; common to diesel engines, the EGR System is designed to enhance fuel efficiency in heavy-load and uphill towing situations. Heavy-duty cooling further enhances performance.

+ Fuel-efficient performance is engineered into the electro-mechanical heart of the 6.4-liter HEMI V8. Operating with seamless precision, our MDS/Fuel Saver Technology helps save fuel with no compromise or noticeable changes in engine operation. While cruising at highway speeds, the engine shuts off four of the eight cylinders, maintaining speeds with four-cylinder-like efficiency.

+ **Best-in-class[‡] payload** rounds it out. A Ram 3500 equipped with the available 6.4-liter HEMI V8 delivers a top-tier payload rating of 7,390 lb when properly equipped.

THE TRANSMISSION: *The 5.7-liter HEMI V8 and the 6.4-liter HEMI V8 are mated to the long-proven 66RFE 6-speed automatic. This component delivers heavy-duty levels of capability for towing and hauling. Count on driver-adaptive shifting, three multiple clutch packs, dual filters on a dual-stage pump and an independent lubrication cooler to ensure ample pressures—and peace of mind—under all driving situations and towing/hauling conditions.*

RAM TOUGH TRANSFER CASES

The two transfer cases employed by Ram 2500/3500 Heavy Duty are exactly what you need for ultra-4x4 capability. The BorgWarner BW 44-46 transfer case features responsive electronic shift-on-the-fly engineering, with three operating ranges, plus Neutral.

The manually activated BW 44-47 transfer case also features three operating ranges, plus Neutral. Both of these impressive units offer a low-range reduction ratio of 2.64:1—an ideal ratio when off road in a slow rock-climbing situation, or when using your Ram 4x4 on challenging terrain or steep grades. You need capability and performance that exceeds the need, and Ram Heavy Duty pickups are designed to excel.



A MONSTER

6.7L CUMMINS® TURBO DIESEL 385 HP • 900 LB-FT OF TORQUE

Proven in worldwide use, the 6.7L Cummins Turbo Diesel is engineered to the tolerances and durability to power semi-class big rigs. As available diesel engine for Ram 2500/3500 Heavy Duty, each of the three Cummins calibrations specifically addresses job-rated use and optimal transmission output. The results give Ram Heavy Duty models uncompromising strength for towing and hauling.

All power outputs of the Cummins feature a next-generation Diesel Exhaust Fluid (DEF) System, a super-efficient Diesel Cooling System with 11-blade fan and,

+ **Best-in-class^[1] diesel towing** for Ram 3500 is part of the Cummins legacy. With the available Cummins High Output Turbo, you can take advantage of that **best-in-class^[1] 900 lb-ft of torque** and 385 horsepower, with towing rated at 31,210 lb. (All towing figures apply to properly equipped trucks.)

+ Incredible torque for Ram 2500 comes from the available Cummins rated at 370 hp and 800 lb-ft, mated to the proven 68RFE 6-speed automatic; this beefed-up powertrain configuration is also available for Ram 3500 models.

+ **The class-exclusive^[1] G56 6-speed manual transmission** is packaged with the 350 hp/660 lb-ft Cummins Turbo Diesel. **The 6-speed manual offers exceptional control when towing and hauling**, and its availability for Ram 2500/3500 clearly separates Ram Heavy Duty from the contenders.

+ **Best-in-class^[1] diesel oil change intervals**—up to 15,000 miles—seriously reduce downtime and costs of regular maintenance.

exclusive to the class,^[1] a “smart” diesel exhaust brake. Output culminates in that best-in-class^[1] available torque of 900 lb-ft that the Cummins High Output churns out in Ram 3500 models.

Cummins + Ram Heavy Duty. It’s a working combination that’s now in excess of two million applications—the ever-growing figure that sums up the enduring quality of this working partnership.

TRANSMISSIONS: *These components are designed to manage awesome levels of torque over decades of use. Packaged with the 350 hp/660 lb-ft Cummins is the class-exclusive^[1] G56 6-speed manual; available for the 370/800 Cummins is the 68RFE automatic. For the Cummins High Output Turbo Diesel and its best-in-class^[1] 900 lb-ft of available torque, the AISIN® Heavy-Duty 6-speed automatic transmission ably steps up to the task.*



The AISIN Heavy-Duty 6-speed automatic is packaged with the available Cummins High Output Turbo Diesel. AISIN advantages include a sophisticated Transmission Control Module which momentarily turns off the exhaust brake (on the Cummins), and a ramped-up Tow/Haul Mode with a more aggressive downshift schedule to meet anticipated commercial-grade hauling demands.

HEAVY-DUTY CONTROL



Properly secure all cargo.



ONLY RAM RIDES ON TECHNOLOGY THIS ADVANCED.

Ram Heavy Duty is the working definition of a “can-do” attitude, with standards that permit no compromise when it comes to capability—or to conventional suspensions. Unique to Ram 2500 is a standard three-link coil spring front suspension and a class-exclusive⁽¹⁾ five-link coil spring rear suspension. Snapshot: innovative Ram engineering for the heaviest loads. Upshot: exceptional comfort and control. So leave the others where they belong—far behind you.

STANDARD HEAVY-DUTY SUSPENSIONS FOR RAM 2500/3500



2500: THE CLASS-EXCLUSIVE⁽¹⁾ FIVE-LINK COIL SPRING REAR SUSPENSION, standard on Ram 2500, is revolutionary in the heavy-duty pickup segment. Engineered to spec, it provides outstanding ride/handling characteristics and beyond-dependable hauling and payload capability, irrespective of load.



3500: THE STANDARD HOTCHKISS LEAF SPRING REAR SUSPENSION capably meets every need for payload and occupant comfort. For Ram 3500 Dually models, the spring package employs separate auxiliary leaves—engineering that helps enhance the rear handling and which also allows for higher payloads.

HEAVY-DUTY CONFIDENCE



WE'LL LEVEL WITH YOU. RAM HEAVY DUTY OWNS THE RIDE.

The true measure of confidence is to invite comparisons, and we're inviting you to find another suspension system as refined as this. The available Auto-Level Rear Air Suspension System for Ram 2500/3500 Heavy Duty is all about the ride—which translates into supreme comfort for occupants and incontestable control when towing and hauling. The Normal Load-Leveling Mode is contrasted with the driver-selectable Alternate Ride Height Mode—invaluable for trailer alignment, and sharply ramping up road manners. No surprise to find it on the same pickup that gives you available best-in-class^[1] towing.* Again, Ram ranks above the rest; for the technical details, see below.

HOW RAM EASILY ADAPTS TO BIG PAYLOADS AND TOUGH TOWING.

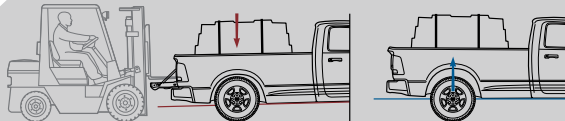

Ram Heavy Duty models know leadership—which you'll see in this groundbreaking technology to help enhance hauling and towing: the available Auto-Level Rear Air Suspension System for Ram 2500/3500 Heavy Duty.

This dual-mode operator-activated system is specifically engineered for the exceptional GVWRs and GCWRs expected from these relentless workers. In Normal Load-Leveling Mode, the system monitors the ride heights on both sides of the vehicle, adjusting for shifts in the load or changes in road surfaces; you'll welcome the constant level load profile and proper headlamp-to-road angle, especially during heavy hauling assignments.

Alternate Ride Height Mode lowers the rear suspension about an inch—just right to keep the hitch/trailer alignment even. This mode establishes capable and comfortable towing by creating a parallel and level relationship between the vehicle and the trailer, ensuring an even "rake" from the front of the pickup through the trailer.

TWO INGENUOUS SOLUTIONS, ONE INDISPENSABLE ADVANTAGE.

2500: THE AVAILABLE AUTO-LEVEL REAR AIR SUSPENSION SYSTEM. Unique to Ram 2500, the engineering is based on the available Ram 1500 Active-Level™ Four-Corner Air Suspension System. This specific adaptation was designed to meet the exacting demands and higher GVWRs and GCWRs of the class.



3500: THE AVAILABLE AUTO-LEVEL REAR AIR SUSPENSION SYSTEM is engineered to meet the ultra-heavy-duty assignments typically met by Ram 3500 single-rear-wheel and dual-rear-wheel models. In this version, leaf springs are augmented with the air springs mounted on top of the axle. The result: air springs work with the leaf springs for ideal handling and performance while hauling big payloads.



*When properly equipped. Properly secure all cargo.

FROM ANY ANGLE, CLEARLY A LEADER.

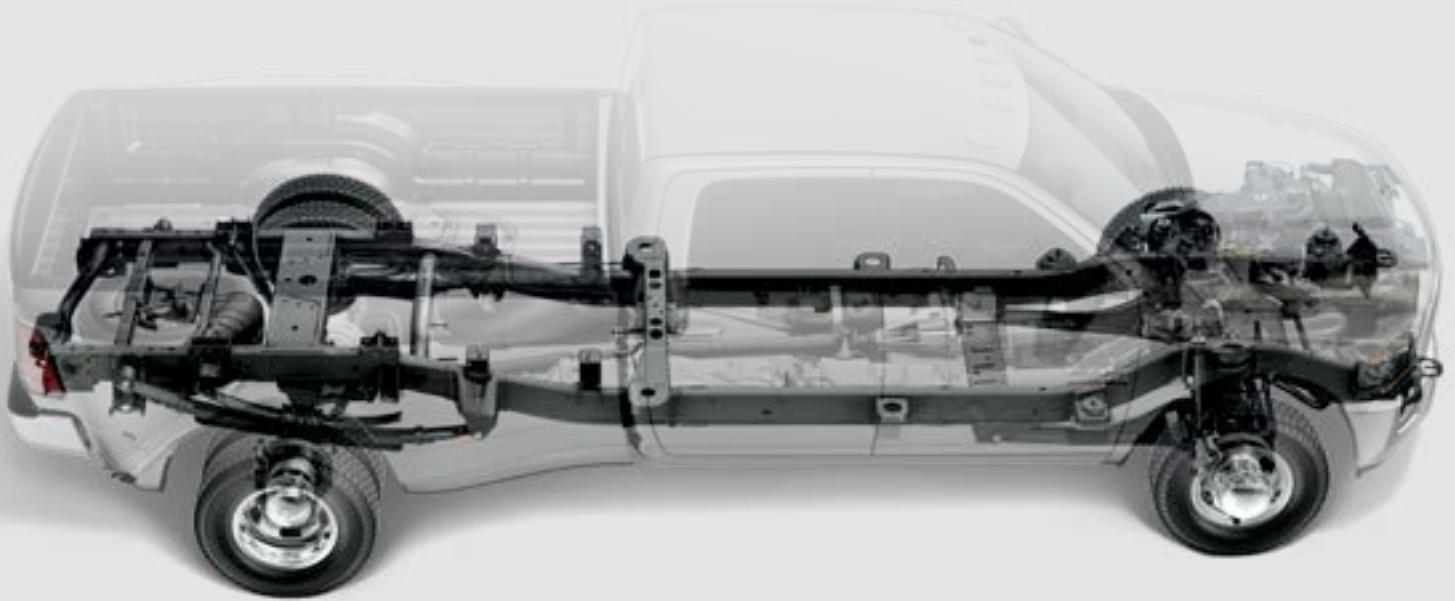

Ram Heavy Duty model frames employ an integrated rear axle crossmember with provisions for an available fifth-wheel and gooseneck hitch. Mounting provisions are integrated into the production box floor and include fifth-wheel pucks, gooseneck bolt plates and gooseneck center castings, with the 7-pin wiring connector mounted directly into the bed.



New for 2016 Ram 2500/3500: Available LED Bed Lighting that welcomes working at night and eliminates adjusting a tonneau cover. Installed right at the factory, this convenient lighting augments the CHMSL-mounted lamp to illuminate the rear area of the cargo bed. With multiple controls—either from the instrument panel-mounted switch or a button on the remote key fob—you have ample illumination on each side of the cargo bed that makes loading and unloading during dark hours easier than ever.



Ram 2500/3500 feature every mechanical advantage for nimble maneuverability—and then we went a step further. For 2016 Heavy Duty, available ParkSense® Front and Rear Park Assist²³ makes parallel parking easier and more convenient than ever.



Shared technology between Ram 2500/3500 also includes the indispensable front axle disconnect, which automatically disengages the front drive axle when reengaging the rear-wheel-drive mode on 4WD models. Our front axle disconnect is engineered with purpose: the design acts to reduce parasitic losses; the overall contribution helps improve fuel efficiency.

The Ram Heavy Duty frame is no-nonsense from the get-go. Tougher, stronger and larger than the previous generation, it features eight tough crossmembers, wide rails and a front rail extension. This two-inch extension positions the front suspension springs slightly outboard, generating more roll stiffness to improve the ride.

The ladder frame features hydroformed front and rear sections with a large front suspension crossmember. The tough roll-formed center rail sections feature an outwardly curved design to help improve rear spring and shock placement.

All Ram 2500/3500 models feature as standard equipment the unique three-link front suspension—and it gets better. Working with the three-link front suspension is an integrated large stabilizer bar to ensure the roll stiffness required by the GVWRs of Ram Heavy Duty—and they are impressive. For Ram 2500, GVWR is rated up to 10,000 lb; for Ram 3500, it vaults up to 14,000 lb.

Whether used for business or pleasure, a Ram Heavy Duty lets you take on the toughest tasks with total confidence. Frame strength is critical; you need resilient stiffness that translates into capability while towing, with the structural integrity that delivers occupant comfort while still hauling big payloads. The 2016 Ram Heavy Duty high-strength steel frames carry the solidity of 50,000-psi steel, providing a Ram tough chassis that'll take on nearly every towing and hauling assignment out there.

A formidable front axle works with a robust front suspension, making Ram Heavy Duty top choice for front-load accessories. Counting on earning a living? Count on a highest snow plow rating of 1,265 lb on 3500 models.²⁴



RAM 2500 CAPABILITY: BEST-IN-CLASS¹ TOWING* AND GCWR SAYS IT ALL.

Ram 2500 Heavy Duty: three-link front suspension for the front axle; electronic 4x4 front axle disconnect; fully integrated rear structural crossmember; results: an outstanding combination of ride, handling and capability.

MAX PAYLOAD*	3,990 LB	MAX TOWING*	17,980 LB
MAX GVWR	10,000 LB	MAX GCWR	25,300 LB



RAM 3500 CAPABILITY: BEST-IN-CLASS¹ TOWING*, PAYLOAD* AND GCWR.

Ram 3500 Heavy Duty: unique three-link front suspension with solid axle; heavy-duty Hotchkiss rear suspension and wide rails; large front suspension crossmember; fully integrated rear structural crossmember; in total, eight high-strength crossmembers with high-strength hydroformed front and rear rail sections.

MAX PAYLOAD*	7,390 LB	MAX TOWING*	31,210 LB
MAX GVWR	14,000 LB	MAX GCWR	39,100 LB



*When properly equipped. Properly secure all cargo.



ROOM WITH
A VIEW.



REFINEMENT

WHERE YOU MOST EXPECT IT.

DRIVER INFORMATION DISPLAY

Your 2016 Ram Heavy Duty pickup is a rolling powerhouse of knowledge, information and communications technology. And it's all in your command: available and customizable full-color, largest-in-class⁽¹⁾ seven-inch multiview display. Some 34 menu options and graphics conveying instant vehicle data. On select models, a six-ring instrumentation cluster. Available 8.4-inch touchscreen (to no one's surprise, Ram Heavy Duty offers the largest in the class⁽²⁾) with some of the most cutting-edge telematics through Uconnect.[®]



LIMITED

LIFE IS GOOD WHEN YOU'RE IN THE BLACK. Step in, and you've stepped up. With its monotone exterior and all-Black 100% leather seats, Ram Heavy Duty Limited makes a powerful statement of understated luxury. This top-of-the-line Heavy Duty features virtually every standard feature you can imagine. Standard heated steering wheel, full-color multiview display, RamBox[®] System and premium NAV system only start the list.



LARAMIE LONGHORN®

STATE-OF-THE-ART. AND YET TIMELESS. Meet the 2016 Ram Heavy Duty Laramie Longhorn: a stunning two-tone exterior complemented by its luxurious interior, with touches that astonish. Think technology and electronics that set the benchmark. European burl wood accents. Beautifully etched leather. Heated and ventilated seats. The lasting impression? Modern instrumentation contrasting with seat buckles that take their cue from the silver watches and spurs of the Old West.





**TOWING.
RAM EXCELS
AT THE CRAFT.**

FAMILY ROOM COMES OF AGE.



Properly secure all cargo.





Convenient driver's-side armrest controls.



Two-tone interior, in Canyon Brown and Light Frost Beige.



Center console with USB port.



Close-up, contrasting Canyon Brown and Light Frost Beige door panel.

LARAMIE®

SOPHISTICATION HAS A BIRTHPLACE. IT'S LARAMIE. This is where it started: a model that made opulence the foundation—and then added on the good stuff, starting with standard monotone and optional two-tone exterior treatments, leather-trimmed interior and invaluable ParkSense® Front and Rear Park Assist.^[2] You can build and price a Laramie model to your exacting specs anytime, at RAMTRUCKS.COM



REDESIGNED CENTER CONSOLE

In a Ram Heavy Duty, the available center console is an all-inclusive operations center, offering at-hand storage and a USB port.

For the 2016 model year, our team improved it, adding a handy cell phone mount and updated cup holders for all models. Here, the Outdoorsman® model is shown with the new open bin console design.





 iConnect[®]

**EVERYTHING YOU NEED
TO STAY CONNECTED.**



DISCOVER NEW PLACES

AT HOME OR ON THE ROAD:
FIND THE BEST RESTAURANTS,
SHOPPING AND ENTERTAINMENT
VENUES—WITH A QUICK SEARCH.*

*Certain features not available
while vehicle is in motion.



START YOUR RAM FROM AFAR

WARM UP THE ENGINE AND CABIN,
UNLOCK YOUR DOORS OR FLASH YOUR
HEADLAMPS JUST BY USING
YOUR PHONE.^[5]



NAVIGATE YOUR ADVENTURES

GET TURN-BY-TURN DIRECTIONS
TO WHEREVER YOU'RE GOING—AND
DON'T HESITATE TO EXPLORE
ONCE IN A WHILE.



LISTEN TO MUSIC, TALK SHOWS AND SPORTS

ACCESS IT ALL, AND ALL THE TIME.
SIRIUSXM® SATELLITE RADIO^[4] LETS
YOU TUNE IN YOUR FAVORITES:
ARTISTS, RADIO HOSTS AND
(WE HOPE) WINNING TEAMS.



DRAG AND DROP

NEW FOR UCONNECT® SELECT
FROM A MENU OF APPS AND DRAG
YOUR CHOICES INTO PLACE
ALONG THE BOTTOM ROW FOR
EASY CUSTOMIZATION.

9-1-1

ASSIST IN EMERGENCIES

IT'S INVALUABLE AND POTENTIALLY
LIFE-SAVING. ACCESS 9-1-1 CALL^[6]
AND ROADSIDE ASSISTANCE^[9] WITH
THE TOUCH OF A BUTTON.



HOST A HOTSPOT

UPLOAD AND DOWNLOAD, POST AND
SEARCH. UCONNECT WITH AVAILABLE
WIFI HOTSPOT^[10] LETS YOU CONNECT
YOUR DEVICES DIRECTLY TO THE WEB.

[†]Additional charges apply.



SPEAK UP AND BE HEARD

MAKE AND RECEIVE CALLS.
SEND AND GET TEXTS^[6] (NOT
COMPATIBLE WITH IPHONE®)—
ALL WHILE DRIVING SAFELY,
WITH HANDS-FREE^[7] CAPABILITY.



SEE INTO THE FUTURE

TAKE ADVANTAGE OF WEATHER AND
TRAFFIC REPORTS WITH A FIVE-YEAR
TRIAL SUBSCRIPTION[†] TO SIRIUSXM®
TRAVEL LINK^[4] AND SIRIUSXM TRAFFIC^[4]

[†]Available on select Uconnect systems.
See dealer for details.

RAM HEAVY DUTY





Revised center console, now with cell phone holder.



In-door storage bins are oversized for large bottles.



Center storage doubles as a writing surface.



Dual glove boxes.



Available in-floor storage bins and under-the-seat storage spaces for Crew Cab models.



Available fold-flat load floors on Ram Heavy Duty Crew Cab models.

Properly secure all cargo.

RAMBOX® CARGO MANAGEMENT SYSTEM^[1]



The multi-purpose cargo bed extender/divider gives you expanded versatility for any items you're planning to haul. With the tailgate open, it can be mounted to extend the storage area while still keeping things secure. It can also be moved throughout the bed to act as a cargo divider and conveniently stores at the front of the bed when not in use.



The RamBox System bins greatly broaden cargo-carrying capability and convenience. Add any of the numerous available Authentic Accessories from Mopar[®]—like this RamBox Cargo Organizer—and it's clear why Ram Heavy Duty is the go-to truck for storage and functionality.



THE AVAILABLE CLASS-EXCLUSIVE[®] RAMBOX CARGO MANAGEMENT SYSTEM.

Make your Ram 2500/3500 stand out in every field. The ingenious RamBox System starts with two large, drainable, illuminated and lockable bed-side storage bins for everything from tools to sports equipment. The comprehensive system also includes a cargo bed extender/divider, cargo bed rails with four adjustable tie-down cleats, and, for 2016, the new LED Bed Lighting. It's factory-installed on Ram 2500/3500 models with the 6'4" bed—and is engineered to leave room for standard sheets of building materials.

Tie-down points merely start the story of capability offered by the RamBox System cleats. Movable along the bed-side rails, you can adjust each cleat to correctly—and securely—lock in your cargo.



**EAGERLY TAKES ON ROADS
LESS TRAVELED.**

POWER WAGON®

IT'S THE MOST CAPABLE OFF-ROAD FULL-SIZE PICKUP.^[3] This 4x4 Crew Cab 2500 welcomes remote locations and the toughest vocations. Standard: 6.4-liter HEMI® V8 with MDS, 410hp/429lb-ft of torque; solid axles fore and aft, both with electronically locking differentials; generous additional front axle articulation via the electronic disconnecting sway bar; 4.10:1 axle ratio; 14.3-inch ground clearance, with 33.6-degree approach/26.2-degree departure angles—plus multiple skid plates; heavy-duty Bilstein® monotube shocks; front-mounted 12,000-lb-rated WARN® winch with quarter-inch aircraft cable, all of it riding on monster 33-inch Goodyear® Wrangler DuraTrac tires. This is the one Heavy Duty pickup when you're going to extremes. **The 2016 Ram Power Wagon.**

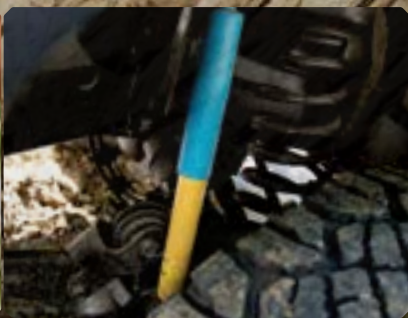

RAM 2500/3500 DIMENSIONS

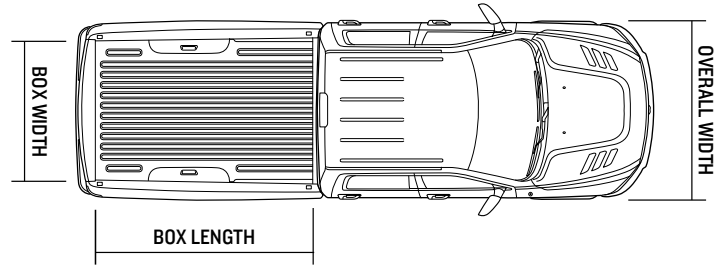
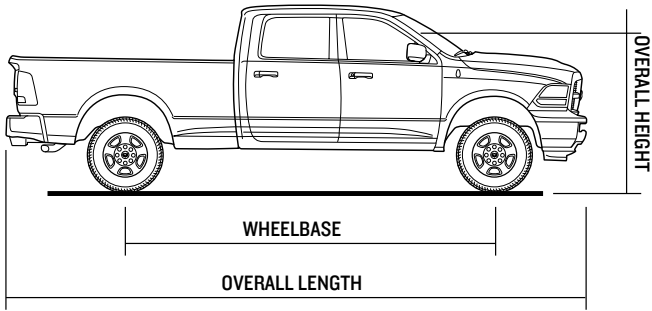

RAM HEAVY DUTY CREW CAB WITH 8' BOX SHOWN

RAM HEAVY DUTY INTERIOR DIMENSIONS

All dimensions are in inches unless otherwise noted.

	REGULAR CAB	CREW CAB	MEGA CAB®
HEAD ROOM, FRONT/REAR	39.9	41.0 / 39.9	41.0 / 40.3
LEG ROOM, FRONT/REAR	41.0	41.0 / 40.3	41.0 / 43.3
SHOULDER ROOM, FRONT/REAR	66.0	66.0 / 65.7	66.0 / 65.7
HIP ROOM, FRONT/REAR	62.9	63.2 / 63.2	63.2 / 63.2
BEHIND SECOND ROW (CU FT)	N/A	N/A	12.1
TOTAL INTERIOR VOLUME (CU FT)	62.5	125.3	142.65

RAM 2500 EXTERIOR DIMENSIONS

All specs are for base models only; in inches unless otherwise noted.

	REGULAR CAB	CREW CAB		MEGA CAB®
	8' BOX	6'4" BOX	8' BOX	6'4" BOX
OVERALL BODY WIDTH	79.4	79.4	79.4	79.4
OVERALL HEIGHT (4x2 / 4x4)	76.2 / 78.1	76.9 / 78.8	76.7 / 78.6	77.9 / 79.8
OVERALL LENGTH	230.4	237.3	259.4	248.4
TRACK — FRONT (4x2 / 4x4)	68.7 / 68.7	68.7 / 68.7	68.7 / 68.7	67.7 / 67.7
TRACK — REAR (4x2 / 4x4)	68.1 / 68.1	68.1 / 68.1	68.1 / 68.1	67.1 / 67.1
WHEELBASE (4x2 / 4x4)	140.2 / 140.4	149.1 / 149.3	169.1 / 169.3	160.2 / 160.4
BOX HEIGHT	20.2	20.1	20.2	20.1
BOX LENGTH	98.3	76.3	98.3	76.3
BOX WIDTH, WALL TO WALL	66.4	66.4	66.4	66.4
BOX WIDTH, BETWEEN WHEELHOUSINGS	51	51	51	51

RAM 3500 EXTERIOR DIMENSIONS

All specs are for base models only; in inches unless otherwise noted.

	REGULAR CAB		CREW CAB			MEGA CAB®	
	8' BOX	8' BOX DRW	6'4" BOX	8' BOX	8' BOX DRW	6'4" BOX	6'4" BOX DRW
OVERALL WIDTH	79.4	96.4	79.4	79.4	96.4	79.4	96.4
OVERALL HEIGHT (4x2 / 4x4)	77.7 / 79.1	77.7 / 79.1	78.4 / 79.8	77.4 / 79.6	77.4 / 79.6	78.3 / 79.7	77.5 / 79.0
OVERALL LENGTH	230.4	230.4	237.3	259.3	259.3	248.4	248.4
TRACK — FRONT (4x2 / 4x4)	67.7 / 67.7	68.6 / 69.5	67.7 / 67.7	67.7 / 67.7	68.6 / 69.5	67.7 / 67.7	68.6 / 69.5
TRACK — REAR (4x2 / 4x4)	67.1 / 67.1	75.8 / 75.8	67.1 / 67.1	67.1 / 67.1	75.8 / 75.8	67.1 / 67.1	75.8 / 75.8
WHEELBASE (4x2 / 4x4)	140.0 / 140.4	140.0 / 140.4	148.9 / 149.3	168.9 / 169.3	168.9 / 169.3	160.0 / 160.4	160.0 / 160.4
BOX HEIGHT	20.2	20.2	20.1	20.2	20.2	20.1	20.1
BOX LENGTH	98.3	98.3	76.3	98.3	98.3	76.3	76.3
BOX WIDTH, WALL TO WALL	66.4	66.4	66.4	66.4	66.4	66.4	66.4
BOX WIDTH, BETWEEN WHEELHOUSINGS	51	51	51	51	51	51	51

RAM 2500/3500 SRW WHEELS

3500 DRW WHEELS



17-inch Steel, Argent Painted Finish
Standard on 2500 Tradesman® (WDA)



17-inch Polished Aluminum
Standard on 2500 Power Wagon® Models (WVU)



18-inch Steel, Argent Painted Finish
Standard on 3500 Tradesman
Optional on 2500 Tradesman (WBN)



17-inch Steel, Argent Painted Finish
Standard on Tradesman (WFU)



18-inch Steel, Chrome-Clad
Standard on SLT
Optional on Tradesman (WBH)



18-inch Polished Aluminum
Standard on Big Horn®/Lone Star® and
Outdoorsman® ■ Optional on SLT (WBE)



18-inch Polished Aluminum
Standard on Laramie® (WBL)



17-inch Steel, Chrome Finish
Standard on SLT and Big Horn/Lone Star®
Optional on Tradesman (WD4)



18-inch Polished Aluminum
with Painted Pockets
LEFT: White Gold Standard on Laramie Longhorn®
with Two-Tone Exterior Paint (WBM)
RIGHT: Silver Standard on Laramie Longhorn with available
Monotone Exterior Paint (WBA)



20-inch Polished Aluminum
with White Gold Pockets
Optional on Laramie Longhorn with
Two-Tone Exterior Paint (WRK)



20-inch Painted Satin Carbon Aluminum
with Chrome Inserts
Optional on SLT, Big Horn/Lone Star®, Outdoorsman
and Laramie (WRJ)



17-inch Polished Aluminum
Standard on Laramie and Limited
Optional on SLT and Big Horn/Lone Star® (WF7)



20-inch Aluminum Black Painted
Included with Black Appearance Group
and Sport Appearance Group (WF3)



20-inch Polished Aluminum
with Silver Pockets
Optional on Laramie Longhorn with available
Monotone Exterior Paint (WRA)



20-inch Painted Aluminum
with Chrome Pockets
Standard on Limited (WH3)



17-inch Polished Aluminum
with Unique Longhorn Center Cap
Standard on Laramie Longhorn (WF9)

CONFIGURATIONS

	Cab			Box		Box, 3500 Only		Seating	
	Regular Cab	Crew Cab	Mega Cab*	SRW: 6'4" Box	SRW: 8' Box	DRW: 6'4" Box	DRW: 8' Box	40/20/40 Bench Seats	Bucket Seats
2500/3500 Tradesman	•	•	N/A	Available with Crew Cab	Available with Reg Cab or Crew Cab	N/A	Available with Reg Cab or Crew Cab	•	N/A
2500/3500 SLT	•	•	•	Available with Crew Cab or Mega Cab	Available with Reg Cab or Crew Cab	Available with Mega Cab	Available with Reg Cab or Crew Cab	•	Optional
2500/3500 Big Horn/Lone Star*	N/A	•	•	Available with Crew Cab or Mega Cab	Available with Crew Cab	Available with Mega Cab	Available with Crew Cab	•	Optional
2500 Outdoorsman	N/A	•	N/A	•	•	N/A	N/A	Optional	•
2500 Power Wagon Tradesman	N/A	•	N/A	•	N/A	N/A	N/A	•	N/A
2500 Power Wagon	N/A	•	N/A	•	N/A	N/A	N/A	•	N/A
2500 Power Wagon Laramie	N/A	•	N/A	•	N/A	N/A	N/A	•	N/A
2500/3500 Laramie	N/A	•	•	Available with Crew Cab or Mega Cab	Available with Crew Cab	Available with Mega Cab	Available with Crew Cab	•	Optional
2500/3500 Laramie Longhorn	N/A	•	•	Available with Crew Cab or Mega Cab	Available with Crew Cab	Available with Mega Cab	Available with Crew Cab	N/A	•
2500/3500 Limited	N/A	•	•	Available with Crew Cab or Mega Cab	Available with Crew Cab	Available with Mega Cab	Available with Crew Cab	N/A	•

*Lone Star model available only in Texas.

RAM 2500/3500 TRIM LEVELS

TRADESMAN®

Tough, no-nonsense capability for the workman



POWERTRAIN

- 5.7L HEMI® V8/6-speed automatic (26A)
- 6.4L HEMI V8 Multi-Displacement System (MDS)/6-speed automatic (22A)
- 6.7L I6 Cummins® Turbo Diesel/6-speed manual (2EA)
- 6.7L I6 Cummins Turbo Diesel/6-speed automatic (2FA)
- 6.7L I6 Cummins High Output Turbo Diesel/6-speed AISIN® automatic (28A) (3500 only)

STANDARD FEATURES:



INTERIOR AMENITIES

- Air conditioning
- Heavy-duty vinyl 40/20/40 split-bench seat
- Black vinyl floor covering
- Mini floor console
- Instrument panel Black bezel
- Tinted windows
- Rear fixed window
- Rearview day/night mirror
- 12-volt auxiliary power outlet
- Speed control
- 6-speaker audio system
- Manual 6 x 9-inch Black mirrors
- Automatic headlamps
- Tilt steering column
- Instrument cluster with 3.5-inch Driver Information Display
- Radio 3.0 AM/FM
- Media Hub with audio input jack and remote USB port

EXTERIOR FEATURES

- Painted steel wheels
- Black front and rear bumper
- Black grille
- Quad-lens halogen headlamps
- Incandescent taillamps
- Black door handles
- Body-color headlamp filler panel

SAFETY & SECURITY

- Six air bags^[1] including driver and front-passenger, side-curtain and front seat side-mounted
- Four-wheel antilock disc brakes
- Locking tailgate
- Electronic Stability Control (ESC)^[2]
- Sentry Key® Theft Deterrent System
- Variable/intermittent windshield wipers
- Tire Pressure Monitoring Display (2500)
- Tire Pressure Information System (3500)

CAPABILITY & FUNCTIONALITY

- Manual shifting, part-time 4x4 transfer case
- Conventional front and rear differentials
- Dual 730-amp maintenance-free batteries (with available Cummins)
- Heavy-duty engine cooling
- Heavy-duty front and rear shock absorbers
- Front stabilizer bar
- Class V hitch receiver
- Trailer tow with 4- and 7-pin wiring harness connector

POWER WAGON® TRADESMAN

Built for extreme work—and the extreme off-road
2500 Crew Cab only



POWERTRAIN

- 6.4L HEMI V8 MDS/6-speed automatic (22B)

INCLUDES SELECT FEATURES FROM TRADESMAN, PLUS:



EXTERIOR FEATURES

- Fog lamps
- Chrome rear bumper
- Black headlamp filler panel
- Chrome front bumper
- Black wheel flares
- 17-inch polished aluminum wheels
- LT285/70R17D OWL All-Terrain tires
- Power Wagon tailgate decal

CAPABILITY & FUNCTIONALITY

- 180-amp alternator
- Hill Descent Control
- 4.10 rear axle ratio
- Tru-Lok® front and rear electronic locking axles
- Front electronic disconnecting stabilizer bar
- Bilstein® performance front and rear shocks
- Tow hooks
- Fuel tank skid plate shield
- Transfer case skid plate shield
- Front 12,000-lb WARN® winch

RAM 2500/3500 TRIM LEVELS

SLT

Uncompromising strength with welcome touches of comfort



POWERTRAIN

- 5.7L HEMI® V8/6-speed automatic (26G)
- 6.4L HEMI V8 Multi-Displacement System (MDS)/6-speed automatic (22G)
- 6.7L I6 Cummins® Turbo Diesel/6-speed manual (2EG)
- 6.7L I6 Cummins Turbo Diesel/6-speed automatic (2FG)
- 6.7L I6 Cummins High Output Turbo Diesel/6-speed AISIN® automatic (28G) (3500 only)

INCLUDES SELECT TRADESMAN® FEATURES, PLUS:



INTERIOR AMENITIES

- Cloth 40/20/40 bench seat
- Premium vinyl door trim with map pocket
- Carpet floor covering
- Front and rear floor mats
- Overhead console with map lights
- Chrome accent shift knob
- Uconnect® 5.0 touchscreen system with Bluetooth® Voice Command^[7]
- Remote USB charge-only port
- Rearview mirror with microphone
- Rear power-sliding window
- Instrument panel color-keyed bezel

EXTERIOR FEATURES

- Chrome front and rear bumpers
- Chrome grille
- Chrome door handles
- Steel chrome-clad wheels

CAPABILITY & FUNCTIONALITY

- Electronic shifting, part-time 4x4 transfer case
- Remote Keyless Entry with AllSecure®
- Electronic trailer brake controller

POWER WAGON®

The traditional Power Wagon: capability to the max
2500 Crew Cab only



POWERTRAIN

- 6.4L HEMI V8 MDS/6-speed automatic (22P)

INCLUDES SELECT SLT FEATURES, PLUS:



EXTERIOR FEATURES

- Premium LED taillamps — Black
- Bifunctional projector headlamps — Black
- Clearance lamps
- Fog lamps
- Black headlamp filler panel
- Chrome grille surround with billets
- Black wheel flares
- Two-tone paint with Black lower
- 17-inch polished aluminum wheels
- LT285/70R17D OWL All-Terrain tires
- Power Wagon graphic decals

CAPABILITY & FUNCTIONALITY

- Hill Descent Control
- 180-amp alternator
- Manual shifting, part-time 4x4 transfer case
- 4.10 rear axle ratio
- Tru-Lok® front and rear electronic locking axles
- Front electronic disconnecting stabilizer bar
- Bilstein® performance front and rear shocks
- Tow hooks
- Fuel tank skid plate shield
- Transfer case skid plate shield
- Front 12,000-lb WARN® winch

POWER WAGON GRAPHICS

Tailgate Graphic	Standard		
Hood Decal	Standard		
Side Graphic	Standard		
Chrome Grille Surround with Red Billets	Standard (color-dependent)		
Exterior Color	Red Graphics	Gray Graphics	Red Grille
Bright White	X		X
Brilliant Black Crystal Pearl (Monotone)	X		X
Bright Silver Metallic	X		X
Granite Crystal Metallic	X		X
Flame Red		X	X
True Blue Pearl		X	
Maximum Steel Metallic		X	
Delmonico Red Pearl		X	
Blue Streak Pearl		X	

RAM 2500/3500 TRIM LEVELS

BIG HORN®/LONE STAR*

Subtle upgrades inside and out—with its own brand for Texas



POWERTRAIN

- 5.7L HEMI® V8/6-speed automatic (26Z/26Y)
- 6.4L HEMI V8 Multi-Displacement System (MDS)/6-speed automatic (22Z/22Y)
- 6.7L I6 Cummins® Turbo Diesel/6-speed manual (2EZ/2EY)
- 6.7L I6 Cummins Turbo Diesel/6-speed automatic (2FZ/2FY)
- 6.7L I6 Cummins High Output Turbo Diesel/6-speed AISIN® automatic (28Z/28Y) (3500 only)

INCLUDES SELECT SLT FEATURES, PLUS:



INTERIOR AMENITIES

- Premium cloth 40/20/40 bench seat with 10-way power adjustment and power lumbar control on the driver's side
- Leather-wrapped steering wheel with remote audio controls
- 115-volt power outlet
- Fold-flat load floor (Crew Cab)
- 60/40 split-folding rear seat

EXTERIOR FEATURES

- Fog lamps
- Chrome grille surround with billetes
- 18-inch polished aluminum wheels (SRW)
- 17-inch steel wheels with chrome finish (DRW)
- Big Horn tailgate badge

SAFETY & SECURITY

- Remote Start System (automatic transmission only)

CAPABILITY & FUNCTIONALITY

- Antispin differential rear axle



AVAILABLE BLACK APPEARANCE GROUP

Includes:

- Black painted front and rear bumpers
- Black grille
- Black badges for fender/doors/tailgate
- Black bezel quad-lens halogen headlamps
- Black door handles
- 20-inch Black painted aluminum wheels
- ParkView® Rear Back-Up Camera^[2]

OUTDOORSMAN®

This outfit is designed exclusively for the sportsman
2500 Crew Cab only



POWERTRAIN

- 5.7L HEMI V8/6-speed automatic (26T)
- 6.4L HEMI V8 MDS/6-speed automatic (22T)
- 6.7L I6 Cummins Turbo Diesel/6-speed manual (2ET)
- 6.7L I6 Cummins Turbo Diesel/6-speed automatic (2FT)^v

INCLUDES SELECT SLT FEATURES, PLUS:



INTERIOR AMENITIES

- Premium cloth bucket seats
- Full-length floor center console (requires automatic transmission)
- Luxury Group
- Front and rear rubber floor mats
- Uconnect® 8.4-inch touchscreen system with Bluetooth® Voice Command^[1]
- Premium cluster with 7-inch Driver Information Display

EXTERIOR FEATURES

- Protection Group
- Tow hooks
- Lower two-tone paint
- On-/off-road tires
- Skid plate
- Painted front and rear bumpers
- Body-color grille
- Accent wheel flares
- Outdoorsman tailgate badge

SAFETY & SECURITY

- Security alarm



AVAILABLE MONOTONE PAINT

- Includes chrome front and rear bumpers and body-color wheel flares

*Lone Star model available only in Texas. Complete features, options and available packages listing for all trim levels in Buyer's Guide.

RAM 2500/3500 TRIM LEVELS

LARAMIE®

Heavy-duty capability joins heavy-duty luxury



POWERTRAIN

- 5.7L HEMI® V8/6-speed automatic (26H)
- 6.4L HEMI V8 Multi-Displacement System (MDS)/6-speed automatic (22H)
- 6.7L I6 Cummins® Turbo Diesel/6-speed manual (2EH)
- 6.7L I6 Cummins Turbo Diesel/6-speed automatic (2FH)
- 6.7L I6 Cummins High Output Turbo Diesel/6-speed AISIN® automatic (28H) (3500 only)

INCLUDES SELECT BIG HORN® FEATURES, PLUS:



INTERIOR AMENITIES

- Leather trim 40/20/40 bench seat
- Ventilated front seats
- Heated front seats
- Deluxe door trim panels
- Dual-Zone Automatic Temperature Control
- Instrument panel woodgrain bezel
- Power 10-way memory driver, 6-way passenger seats
- LED interior lighting
- Heated steering wheel
- Premium 11 10-speaker audio system with subwoofer
- Premium cluster with 7-inch Driver Information Display

EXTERIOR FEATURES

- Premium LED taillamps — chrome
- Chrome exterior mirrors with memory function
- Bifunctional projector headlamps — chrome
- Chrome grille
- Body-color wheel flares
- Laramie badge
- 18-inch polished aluminum wheels (SRW)
- 17-inch polished aluminum wheels (DRW)

CAPABILITY & FUNCTIONALITY

- Security alarm
- ParkView® Rear Back-Up Camera^[2]
- ParkSense® Front and Rear Park Assist^[2]



AVAILABLE TWO-TONE PAINT

- Includes accent-color lower and wheel flares

POWER WAGON® LARAMIE

The off-road giant with the sophistication of a Laramie
2500 Crew Cab only



POWERTRAIN

- 6.4L HEMI V8 MDS/6-speed automatic (22J)

INCLUDES SELECT LARAMIE FEATURES, PLUS:



EXTERIOR FEATURES

- 17-inch polished aluminum wheels
- LT285/70R17D OWL All-Terrain tires
- Power Wagon tailgate badge

CAPABILITY & FUNCTIONALITY

- Hill Descent Control
- 180-amp alternator
- Manual shifting, part-time 4x4 transfer case
- 4.10 rear axle ratio
- Tru-Lok® front and rear electronic locking axles
- Front electronic disconnecting stabilizer bar
- Bilstein® performance front and rear shocks
- Tow hooks
- Fuel tank skid plate shield
- Transfer case skid plate shield
- Front 12,000-lb WARN® winch

RAM 2500/3500 TRIM LEVELS

LARAMIE LONGHORN®

Impressive levels of power and refinement



POWERTRAIN

- 5.7L HEMI® V8/6-speed automatic (26K)
- 6.4L HEMI V8 Multi-Displacement System (MDS)/6-speed automatic (22K)
- 6.7L I6 Cummins® Turbo Diesel/6-speed automatic (2FK)
- 6.7L I6 Cummins High Output Turbo Diesel/6-speed AISIN® automatic (28K) (3500 only)

INCLUDES SELECT LARAMIE® FEATURES, PLUS:



INTERIOR AMENITIES

- Premium leather bucket seats
- Premium door trim panels
- Luxury front and rear floor mats
- Leather-wrapped shift knob
- Full-length premium upgraded floor console
- Laramie Longhorn instrument cluster
- Laramie Longhorn interior accents
- Heated second-row seats
- Uconnect® 8.4 NAV with Bluetooth® Voice Command^[7] and premium navigation
- Premium wood/leather-wrapped steering wheel

EXTERIOR FEATURES

- Cargo Box Lighting
- Accent-color front bumper
- Accent-color rear bumper
- Mopar® door sill guards
- Chrome Laramie Longhorn grille
- Accent-color running boards
- Laramie Longhorn badge
- 18-inch polished aluminum wheels with Gold inserts (SRW)
- 17-inch polished aluminum wheels with Longhorn center cap (DRW)
- Tow hooks

CAPABILITY & FUNCTIONALITY

- Remote Start System
- Spray-in bedliner



AVAILABLE MONOTONE PAINT

- Includes chrome front and rear bumpers, body-color wheel flares, chrome side steps and 18-inch polished aluminum wheels with Silver inserts

LIMITED

A premium all-Black leather interior sets this Ram apart



POWERTRAIN

- 5.7L HEMI V8/6-speed automatic (26M)
- 6.4L HEMI V8 MDS/6-speed automatic (22M)
- 6.7L I6 Cummins Turbo Diesel/6-speed automatic (2FM)
- 6.7L I6 Cummins High Output Turbo Diesel/6-speed AISIN automatic (28M) (3500 only)

INCLUDES SELECT LARAMIE FEATURES, PLUS:



INTERIOR AMENITIES

- Premium leather bucket seats
- Premium door trim panels
- Luxury front and rear floor mats
- Leather-wrapped shift knob
- Full-length premium upgraded floor console
- Limited instrument cluster
- Heated second-row seats
- Uconnect 8.4 NAV Radio with Bluetooth Voice Command^[7] and premium navigation
- Premium wood/leather-wrapped steering wheel

EXTERIOR FEATURES

- Monotone paint
- Body-color front and rear bumpers
- Limited grille
- Limited chrome bodyside molding
- Unique Limited tailgate
- Chrome belt moldings
- Body-color wheel flares
- Wheel-to-wheel side steps (SRW only)
- 20-inch painted aluminum wheels with chrome inserts (SRW)
- 17-inch polished aluminum wheels (DRW)

CAPABILITY & FUNCTIONALITY

- Keyless Enter 'n Go™
- Rain-sensitive windshield wipers
- Auto High-Beam Headlamp Control
- RamBox® Cargo Management System (6'4" box SRW models only)



AVAILABLE CHROME BUMPER PACKAGE

- Includes chrome front and rear bumpers

RAM 2500/3500 EXTERIOR COLORS



Brilliant Black Crystal Pearl



Black Forest Green Pearl



Granite Crystal Metallic



Bright White



Pearl White



Bright Silver Metallic



Flame Red



Delmonico Red Pearl



Luxury Brown Pearl



Blue Streak Pearl



True Blue Pearl



Maximum Steel Metallic

Colors shown in Big Horn® trim.

PAINT COLORS AND TWO-TONE OPTIONS

	Tradesman®	SLT	Big Horn/ Lone Star*	Outdoorsman®	Power Wagon® Tradesman	Power Wagon	Power Wagon Laramie	Laramie®	Laramie Longhorn®	Limited
Delmonico Red	•	•	•	M, ■	•	• ■	•	M, ■	M, ■	•
Flame Red	•	•	•	M	•	• ■	•	M, ■	M	N/A
Luxury Brown	•	•	•	M	•	N/A	•	M, ■	M, ■	N/A
Black Forest	•	•	•	M	•	N/A	•	M, ■	M, ■	N/A
Blue Streak	•	•	•	M, ■	•	• ■	•	M, ■	N/A	N/A
True Blue	•	•	•	M, ■	•	• ■	•	M, ■	M	•
Bright Silver	•	•	•	M, ■	•	• ■	•	M	M	•
Granite Crystal	•	•	•	M, ■	•	• ■	•	M, ■	M	•
Maximum Steel	•	•	•	M	•	• ■	•	M, ■	M	•
Brilliant Black	•	•	•	M	•	M	•	M, ■	M, ■	•
Pearl White	N/A	N/A	N/A	N/A	N/A	N/A	•	M, ■	M, ■	•
Bright White	•	•	•	M	•	• ■	N/A	N/A	N/A	N/A

• = Available Color M = Monotone ■ Black Lower ■ Silver Lower ■ White Gold Lower



Outdoorsman shown in Bright Silver Metallic with Black lower



Laramie shown in Blue Streak Pearl with Silver lower



Laramie Longhorn shown in Luxury Brown Pearl with White Gold lower

To see examples of all possible paint combinations, visit ramtrucks.com

*Lone Star model available only in Texas.

RAM 2500/3500 INTERIOR FABRICS



Vinyl
Diesel Gray
Tradesman® and Power Wagon® Tradesman



Ram Work-Grade Vinyl
Diesel Gray
Tradesman and Power Wagon Tradesman



Sedoso/Alloy Cloth
Diesel Gray
Tradesman, Power Wagon Tradesman, SLT and Power Wagon



Sedoso/Alloy Cloth
Canyon Brown
SLT and Power Wagon



Sedoso/Carbide Premium Cloth
Diesel Gray
SLT, Big Horn®/Lone Star*, Outdoorsman® and Power Wagon



Sedoso/Carbide Premium Cloth
Canyon Brown
SLT, Big Horn/Lone Star*, Outdoorsman and Power Wagon



Bristol Leather/Perforated Leather Trim
Light Frost Beige
Laramie® and Power Wagon Laramie



Bristol Leather/Perforated Leather Trim
Black
Laramie and Power Wagon Laramie



Natura Plus Leather/Perforated Leather with Black Piping and Accent Stitching
Cattle Tan
Laramie Longhorn®

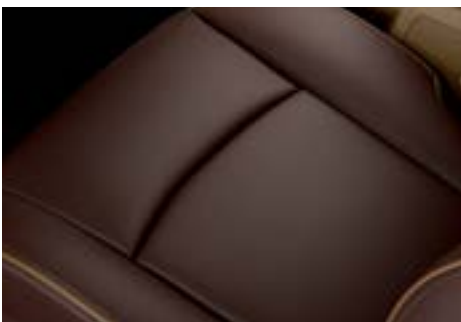

Natura Plus Leather/Perforated Leather with Dark Saddle Piping and Tan Accent Stitching
Canyon Brown
Laramie Longhorn



Natura Plus Leather with Laser Etching/Perforated Leather with Dark Saddle Piping and Tan Accent Stitching
Canyon Brown
Laramie Longhorn



Natura Plus Leather/Perforated Leather with Medium Graystone Piping and Accent Stitching
Black
Limited

*Lone Star model available only in Texas.

RAM 2500/3500 BUYER'S GUIDE

	TRADSMAN [®] REG./CREW	TRADSMAN POWER WAGON [®] CREW	S/T REG./CREW/MEGA	BIGHORN [®] /LONE STAR [®] CREW/MEGA	OUTDOORSMAN [®] CREW	POWER WAGON CREW	LARAMIE [®] CREW/MEGA	LARAMIE POWER WAGON CREW	LARAMIE LONGHORN [®] CREW/MEGA	LIMITED CREW/MEGA
	2TA	2TB	2TG	2TZ/ 2TY	2TT	2TP	2TH	2TJ	2TK	2TM
CPOS PACKAGE										
2500	X	X	X	X	X	X	X	X	X	X
3500 SRW/DRW (6'4" box not available with Crew Cab DRW)	X/X	—	X/X	X/X	—	—	X/X	—	X/X	X/X
ENGINE / TRANSMISSION										
5.7L HEMI [®] Bi-fuel CNG / gas engine / 6-speed automatic (66RFE; 2500 Regular and Crew Cab 8' box only) 383 hp / 400 lb-ft of torque	2TA	—	2TG	—	—	—	—	—	—	—
5.7L HEMI V8 gas engine / 6-speed automatic (66RFE; SRW only) 383 hp / 400 lb-ft of torque	26A	—	26G	26 Z/Y	26T	—	26H	—	26K	26M
6.4L HEMI V8 gas engine with MDS / 6-speed automatic (66RFE) 410 hp / 429 lb-ft of torque (367 hp on Mega Cab [®])	22A	22B	22G	22 Z/Y	22T	22P	22H	22J	22K	22M
6.7L Cummins [®] Turbo Diesel engine / 6-speed manual (G56) 350 hp / 660 lb-ft of torque	2EA	—	2EG	2E Z/Y	2ET	—	2EH	—	—	—
6.7L Cummins Turbo Diesel engine / 6-speed automatic (66RFE) 370 hp / 800 lb-ft of torque	2FA	—	2FG	2F Z/Y	2FT	—	2FH	—	2FK	2FM
6.7L Cummins Turbo Diesel engine / 6-speed AISIN [®] heavy-duty automatic (3500 only) 385 hp / 900 lb-ft of torque	28A	—	28G	28 Z/Y	—	—	28H	—	28K	28M
Diesel Exhaust Fluid (DEF) System (standard with diesel engine)	P	—	P	P	P	—	P	—	P	P
MECHANICAL FEATURES										
ALTERNATOR — 160-amp (standard with gas engine)	S	—	S	S	S	—	S	—	S	S
— 180-amp (standard on diesel; included with 6.4L HEMI V8; included with Snow Plow Prep Group or Snow Chief [®] Group on 5.7L HEMI V8-equipped models)	O/P	S	O/P	O/P	O/P	S	O/P	S	O/P	O/P
— 220-amp (included with Snow Plow Prep Group or Snow Chief Group on diesel- and 6.4L gas-equipped models; also included with dual alternator options)	O/P	—	O/P	O/P	O/P	—	O/P	—	O/P	O/P
— Dual-rated at 380 amps (6.4L gas V8 only; includes 160-amp and 220-amp alternators)	O	O	O	O	O	O	O	O	O	O
— Dual-rated at 440 amps (6.7L diesel only; includes two 220-amp alternators)	O	—	O	O	O	—	O	—	O	O
AXLES — Antispin rear differential (standard on 3500)	O/S	—	O/S	S	S	—	O/S	—	O/S	O/S
— Electronically locking front and rear differentials	—	S	—	—	—	S	—	S	—	—
— 3.42 ratio (standard for diesel)	O	—	O	O	O	—	O	—	O	O
— 3.73 ratio (standard for gas; available for 3500 DRW diesel)	S/O	—	S/O	S/O	S	—	S/O	—	S/O	S/O
— 4.10 ratio (optional for gas; available for 3500 DRW diesel)	O	S	O	O	O	S	O	S	O	O
— 11.5-inch rear — SRW	S	S	S	S	S	S	S	S	S	S
— 11.5-inch rear — 3500 DRW only (included with 6.4L gas engine, diesel / G56 manual transmission, diesel / 66RFE or diesel / AISIN transmission with 3.42 axle ratio)	P	—	P	P	—	—	P	—	P	P
— 11.8-inch rear — 3500 DRW only (included with diesel / AISIN transmission with 3.73 and 4.10 axle ratios)	P	—	P	P	—	—	P	—	P	P
BATTERY — 730-amp, maintenance-free (two required for diesel)	S	S	S	S	S	S	S	S	S	S
DIESEL EXHAUST BRAKE — With "smart" function (included with diesel engine)	P	—	P	P	P	—	P	—	P	P
ELECTRONIC UPFITTER MODULE — N/A with premium speakers	O	O	O	O	O	O	—	—	—	—
ENGINE BLOCK HEATER — Included with Cold Weather Group on diesel-equipped models	O/P	O	O/P	O/P	O/P	O	O/P	O	O/P	O/P
FIFTH-WHEEL/GOOSENECK PREP PACKAGE — Includes in-box 7-pin harness connector (N/A with RamBox [®] Cargo Management System)	O	—	O	O	O	—	O	—	O	O
FUEL TANKS — 8-gallon (included with CNG engine)	P	—	P	—	—	—	—	—	—	—
— 18.2-G.G.E. (gasoline gallon equivalent) dual CNG tanks (included with CNG engine)	P	—	P	—	—	—	—	—	—	—
— 28-gallon (included with Regular Cab models equipped with diesel)	P	—	P	—	—	—	—	—	—	—
— 31-gallon (included with 6'4" box)	S	S	S	S	S	S	S	S	S	S
— 32-gallon (included with 8' box; available with CNG engine)	S/O	—	S/O	S	S	—	S	—	S	S
SHOCKS — Front, heavy-duty	S	—	S	S	S	—	S	—	S	S
— Rear, heavy-duty	S	—	S	S	S	—	S	—	S	S
— Bilstein [®] gas-charged monotube	—	S	—	—	—	S	—	S	—	—
SKID PLATES (4x4) — Transfer case (included in Protection Group and Snowplow Prep Group)	P	S	P	P	S	S	P	S	P	P
— Fuel tank	—	S	—	—	—	S	—	S	—	—
STEERING — Power recirculating ball	S	S	S	S	S	S	S	S	S	S
SUSPENSION — Front, three-link coil spring	S	S	S	S	S	S	S	S	S	S
— Front electronic disconnecting stabilizer bar	—	S	—	—	—	S	—	S	—	—
— Front stabilizer bar	S	—	S	S	S	—	S	—	S	S
— Rear, five-link coil spring (2500 only)	S	S	S	S	S	S	S	S	S	S
— Rear, Hotchkiss leaf spring (3500 only)	S	—	S	S	—	—	S	—	S	S
— Rear, Auto-Level dual-mode Air Spring Suspension System	O	—	O	O	O	—	O	—	O	O
TOW HOOKS — On diesel-equipped models	S	—	S	S	S	—	S	—	S	S
— On gas engine-equipped models (optional on 4x2; included in Protection Group on 4x4; standard on 3500)	O/P/S	S	O/P/S	O/P/S	S	S	O/P/S	S	S	S
TRAILER TOW — 4- / 7-pin trailer harness plug (combination receptacle)	S	S	S	S	S	S	S	S	S	S
— Class V hitch receiver	S	S	S	S	S	S	S	S	S	S
TRANSFER CASES (4x4 models only) — Manual shift-on-the-fly	S	S	—	—	—	S	—	S	—	—
— Electronic shift-on-the-fly	O	—	S	S	S	—	S	—	S	S
WINCH — WARN [®] front, electric, 12,000-lb capacity	—	S	—	—	—	S	—	S	—	—
— Tire carrier	S	S	S	S	S	S	S	S	S	S
EXTERIOR FEATURES										
BEDLINER — Spray-in (not available with Ram 2500 CNG model)	O	O	O	O	O	O	O	O	S	S
BUMPERS — Painted Black	S	—	—	—	—	—	—	—	—	—
— Chrome (included in Chrome Appearance Group and Limited Appearance Group and with Monotone paint)	P	S	S	S	P	S	S	S	P	P
— Painted body color (included with Black Appearance Group)	—	—	—	P	S	—	P	—	S	S
CLEARANCE LAMPS — Cab (included on DRW)	O/P	O	O/P	O/P	O	S	O/P	O	O/P	O/P
— Box and rear fender (included on DRW)	P	—	P	P	—	—	P	—	P	P
DOOR HANDLES — Black (included with low-volume paint or Black Appearance Group)	S	S	P	P	S	S	P	—	—	—
— Chrome	—	—	S	S	—	—	S	—	S	S
FOG LAMPS	—	S	O	S	S	S	S	S	S	S
HEADLAMPS / TAILLAMPS — Automatic headlamps	S	S	S	S	S	S	S	S	S	S
— Quad-halogen headlamps / incandescent taillamps	S	S	S	S	S	—	—	—	—	—
— Premium projector headlamps / premium LED taillamps	—	—	—	—	—	S	S	S	S	S
— Auto High-Beam Headlamp Control (included in Convenience Group)	—	—	—	—	—	—	P	P	P	S
HEADLAMP FILLER PANEL — Black (included with special-order paint)	O	S	O	O	—	S	—	—	—	—
— Body-color	S	—	S	S	S	—	S	—	S	S
LED BED LIGHTING (included with Luxury Group or RamBox System)	O/P	O/P	P	P	S	P	O/P	O/P	S	S

S = Standard, O = Optional, P = Part of Package, — = Not available.
 Note: some features and/or applications may be late availability.

¹Lone Star model available only in Texas.

RAM 2500/3500 BUYER'S GUIDE

	TRADESMAN® REG./CREW	TRADESMAN POWER WAGON® CREW	SLT REG./CREW/MEGA	BIGHORN®/LONE STAR® CREW/MEGA	OUTDOORSMAN® CREW	POWER WAGON CREW	LARAMIE® CREW/MEGA	LARAMIE POWER WAGON CREW	LARAMIE LONGHORN® CREW/MEGA	LIMITED CREW/MEGA
	2TA	2TB	2TG	2TZ/2TY	2TT	2TP	2TH	2TJ	2TK	2TM
CPOS PACKAGE										
EXTERIOR FEATURES (continued)										
MIRRORS — 2500 — Standard size, 6 x 9-inch, Manual (Black; Regular Cab only)	S	—	—	—	—	—	—	—	—	—
— Power / heated (Black; included in Power and Remote Entry Group on Tradesman Regular Cab)	P/S	S	S	S	—	S	—	—	—	—
— Power folding / heated / puddle / turn / auto-dimming (Black; included in Luxury Group)	—	—	P	P	S	P	—	—	—	—
— Power folding / heated / puddle / turn / auto-dimming / memory (chromed)	—	—	—	—	—	—	S	S	S	S
2500 — Available size, 7 x 11-inch (trailer-tow mirrors, two-position foldaway with convex edge) Manual (Black; Regular Cab only)	O	O	—	—	—	—	—	—	—	—
— Power / heated / puddle / turn (Black; requires Power and Remote Entry Group on Tradesman Regular Cab)	O	O	O	O	O	O	—	—	—	—
— Power / heated / puddle / turn / memory (chrome)	—	—	—	—	—	—	O	O	O	O
3500 — Standard size, 7 x 11-inch (trailer-tow mirrors, two-position foldaway with convex edge) Manual (Black; Regular Cab only)	S	—	—	—	—	—	—	—	—	—
— Power / heated / puddle / turn (Black; included in Power and Remote Entry Group)	P	—	S	S	—	—	—	—	—	—
— Power / heated / puddle / turn / memory (chrome)	—	—	—	—	—	—	S	—	S	S
RAMBOX® CARGO MANAGEMENT SYSTEM — With illuminated, lockable, drainable bins on both bed sides; stowable bed divider/extender; LED Bed Lighting and Cargo Rail System with adjustable cleats (Short Box only; SRW only; Tradesman model requires remote keyless entry; N/A with low-volume paints)	O	O	O	O	O	O	O	O	O	S
RUNNING BOARDS	—	—	—	—	—	—	—	—	S	—
SIDE STEPS — Chrome, cab-length; included with Monotone Laramie Longhorn	O	—	O	O	O	—	O	—	O/P	—
— Chrome, wheel-to-wheel; not available on Regular Cab or DRW	O	—	O	O	O	—	O	—	O	S
TONNEAU COVER (not available with Ram 2500 CNG model)	O	O	O	O	O	O	O	O	O	O
WHEEL FLARES — Black	—	S	—	—	—	S	—	—	—	—
— Body-color (included with monotone paint)	—	—	—	—	P	—	S	S	P	S
— Lower body-color	—	—	—	—	S	—	O	—	S	—
WINDSHIELD WIPERS — Variable / intermittent	S	S	S	S	S	S	S	S	S	S
— Rain-sensitive (included in Convenience Group)	—	—	—	—	—	—	P	P	P	S
INTERIOR FEATURES										
AIR CONDITIONING — Manual	S	S	S	S	S	S	—	—	—	—
— Dual-Zone Automatic Temperature Control (Included with Luxury Group or Comfort Group if equipped with 8.4-inch touchscreen system)	—	—	P	P	P	P	S	S	S	S
AUXILIARY INSTRUMENT PANEL SWITCHES — N/A with Comfort Group or with Radio 3.0 or Uconnect® 5.0 system (late availability)	O	—	O	O	O	—	O	—	O	O
CIGAR LIGHTER — Included in Smoker's Group	P	P	P	P	P	P	P	P	P	P
CLUSTER — 3.5-inch Driver Information Display	S	S	S	S	—	S	—	—	—	—
— 7-inch Driver Information Display (included in Luxury Group)	—	—	P	P	S	P	S	S	—	—
— 7-inch Driver Information Display (with Laramie Longhorn filigree)	—	—	—	—	—	—	—	—	S	—
— 7-inch Driver Information Display (with unique Limited detail)	—	—	—	—	—	—	—	—	—	S
CONSOLE — Mini floor console (included with 6-speed manual transmission or manual transfer case)	P	S	P	P	P	S	P	S	—	—
— Full-size floor console (included with bucket seats)	—	—	P	P	P	—	P	—	S	S
— Overhead console	—	—	S	—	—	S	—	—	—	—
— Overhead console with Universal Garage Door Opener (included in Luxury Group)	—	—	P	P	S	P	S	S	S	S
DOOR LOCKS — Manual door locks (Regular Cab only)	S	—	—	—	—	—	—	—	—	—
— Power door locks (included in Power and Remote Entry Group on Tradesman Regular Cab)	P/S	S	S	S	S	S	S	S	S	S
— Keyless Enter™ n Go™	—	—	—	—	—	—	O	O	O	S
FLOOR COVERING — Black vinyl (not available on Mega Cab®)	S	S	O	O	O	O	—	—	—	—
— Carpet (included in Popular Equipment Group)	P	P	S	S	S	S	S	S	S	S
MIRRORS — Rearview day/night	S	S	S	—	—	S	—	—	—	—
— Rearview day/night with microphone (included with Radio 3.0, Uconnect 5.0, 8.4 and 8.4 NAV systems without Luxury Group)	—	—	P	S	—	—	—	—	—	—
— Rearview auto-dimming with microphone (included with Luxury Group)	—	—	P	P	S	P	S	S	S	S
— Rearview auto-dimming with video display (included with Cargo-View Camera ² in combination with ParkView® Rear Back-Up Camera ² or with Radio 3.0 and ParkView Rear Back-Up Camera ²)	P	P	P	P	P	P	P	P	P	P
— Recall/Ecall buttons (packaged with Uconnect 8.4 and 8.4 NAV systems)	—	—	P	P	P	P	S	S	S	S
PEDALS — Non-adjustable	S	S	S	S	S	S	S	S	—	—
— Power-adjustable (requires automatic transmission)	—	—	O	O	O	O	—	—	—	—
— Power-adjustable with memory (requires automatic transmission)	—	—	—	—	—	—	O	O	S	S
POWER SUNROOF (not available with Regular Cab)	—	—	O	O	O	O	O	O	O	O
SEATS — Manually adjustable driver and front-passenger (included with *TX and *V9)	S	S	S	—	—	S	—	—	—	—
— Ten-way power driver's and manual front-passenger (included with *M9 and *MJ)	—	—	P	S	S	P	—	—	—	—
— Ten-way power driver's with memory and 6-way power front-passenger (included with *VL, *GJ, *XJ, *DJ & *UL)	—	—	—	—	—	—	S	S	S	S
— Two-way power lumbar support (included with *M9 and *MJ)	—	—	P	S	S	P	S	S	S	S
— Heated front (included in Comfort Group)	—	—	—	P	P	P	S	S	S	S
— Heated rear (Crew Cab and Mega Cab® only; included with *GJ)	—	—	—	—	—	—	P	—	S	S
— Ventilated front	—	—	—	—	—	—	S	S	S	S
— Vinyl 40/20/40 split-bench front with folding front armrest/cup holder (*TX)	S	S	—	—	—	—	—	—	—	—
— Ram work-grade vinyl 40/20/40 split-bench front with folding front armrest/cup holder (*SX)	O	O	—	—	—	—	—	—	—	—
— Cloth 40/20/40 split-bench front, front armrest with cup holder (*V9)	O	O	S	—	—	S	—	—	—	—
— Premium cloth-trimmed 40/20/40 split-bench front, front armrest with cup holder (*M9)	—	—	O	S	O	O	—	—	—	—
— Premium cloth-trimmed low-back bucket with full-length floor console (*MJ)	—	—	O	O	S	—	—	—	—	—
— Leather-trimmed 40/20/40 split-bench heated and ventilated front (*VL)	—	—	—	—	—	—	S	S	—	—
— Leather-trimmed high-back, ventilated and heated bucket with full-length floor console (*GJ)	—	—	—	—	—	—	O	—	—	—
— Premium leather with laser-etched design, high-back ventilated and heated bucket with premium full-length floor console (available only in Canyon Brown) (*XJ)	—	—	—	—	—	—	—	—	S	—
— Premium leather high-back, ventilated and heated bucket with premium full-length floor console (available in Canyon Brown or Cattle Tan) (*DJ)	—	—	—	—	—	—	—	—	O	—
— Premium Natura leather high-back, ventilated and heated bucket with premium full-length floor console (available only in Black) (*UL)	—	—	—	—	—	—	—	—	—	S
STEERING WHEEL — Urethane	S	S	S	—	—	S	—	—	—	—
— Leather-wrapped with audio controls (included in Luxury Group)	—	—	P	S	S	P	—	—	—	—
— Leather-wrapped, heated with audio controls (included in Comfort Group)	—	—	—	P	P	P	S	S	—	—
— Leather-wrapped, heated, with real wood and audio controls	—	—	—	—	—	—	—	—	S	S

S = Standard. O = Optional. P = Part of Package. — = Not available.
 Note: some features and/or applications may be late availability.

RAM 2500/3500 BUYER'S GUIDE

	TRADESMAN® REG./CREW	TRADESMAN POWER WAGON® CREW	S/T REG./CREW/MEGA	BIGHORN®/LONE STAR® CREW/MEGA	OUTDOORSMAN® CREW	POWER WAGON CREW	LARAMIE® CREW/MEGA	LARAMIE POWER WAGON CREW	LARAMIE LONGHORN® CREW/MEGA	LIMITED CREW/MEGA
	2TA	2TB	2TG	2TZ/2TY	2TT	2TP	2TH	2TJ	2TK	2TM
CPOS PACKAGE										
INTERIOR FEATURES (continued)										
STORAGE — Behind the seat (Regular Cab and Mega Cab [®])	S	—	S	S	S	—	S	—	S	S
— Front center-seat-cushion storage (included with remote CD player and with *VL and *M9 seats)	P	P	P	P	P	P	P	P	—	—
— Rear, under-seat compartment (Crew Cab only)	S	S	S	S	S	S	S	S	S	S
— Rear, in-floor storage boxes (Crew Cab only)	S	S	S	S	S	S	S	S	S	S
— Flat-folding load floor (Crew Cab only; included in *M9 seats and above)	—	—	P	S	S	P	S	S	S	S
VISORS — Passenger-side, with vanity mirror	—	—	S	S	—	S	—	—	—	—
— Driver and passenger-side, with illuminated vanity mirror (included with Luxury Group)	—	—	P	P	S	P	S	S	S	S
WINDOWS — Manual windows (Regular Cab only)	S	—	—	—	—	—	—	—	—	—
— Power windows, front one-touch down (Regular Cab; included in Power and Remote Entry Group)	P	—	S	—	—	—	—	—	—	—
— Power windows, front one-touch up/down (Crew Cab and Mega Cab)	S	S	S	S	S	S	S	S	S	S
— Rear fixed window	S	S	—	—	—	—	—	—	—	—
— Rear sliding window, manual (Regular Cab)	O	—	S	—	—	—	—	—	—	—
— Rear sliding window, power (Crew Cab and Mega Cab)	—	—	S	S	S	S	S	S	S	S
— Rear window defroster (requires rear sliding window)	—	—	O	O	O	O	O	O	O	O
UCONNECT® MULTIMEDIA										
CONNECTIVITY — 12-volt DC auxiliary	S	S	S	S	S	S	S	S	S	S
— 115-volt AC auxiliary (included with *M9 and *MJ seats)	—	—	P	S	S	P	S	S	S	S
— 2.5-amp charging USB port (included with Uconnect 5.0, 8.4 and 8.4 NAV systems or *M9 and *MJ seats)	P	P	P	P	P	P	S	S	S	S
MEDIA HUB — 1.5-amp fully functional USB port, auxiliary jack for mobile devices (included with Radio 3.0 and Uconnect 5.0 system)	S	S	S	S	—	S	—	—	—	—
— 1.5-amp fully functional USB port, auxiliary jack for mobile devices and SD card slot (included with Uconnect 8.4 and 8.4 NAV systems)	—	—	P	P	S	P	S	S	S	S
RADIOS — 3.0 AM/FM	S	S	—	—	—	—	—	—	—	—
— Uconnect 5.0 AM/FM/SAT/Bluetooth [®] (5-inch touchscreen display)	O	O	S	S	—	S	—	—	—	—
— Uconnect 8.4 AM/FM/SAT/Bluetooth/NAV-ready/Voice Command [™] (8.4-inch touchscreen display)	—	—	O	O	S	O	S	S	—	—
— Uconnect 8.4 NAV AM/FM/SAT/Bluetooth/NAV/Voice Command [™] (8.4-inch touchscreen display)	—	—	—	O	O	O	O	O	S	S
RADIO CONTROLS — Steering wheel-mounted audio controls (included with leather-wrapped steering wheel)	—	—	P	S	S	P	S	S	S	S
RECALL/ECALL — Packaged with Uconnect 8.4 and 8.4 NAV systems	—	—	P	P	S	P	S	S	S	S
SINGLE-DISC CD PLAYER	O	O	O	O	O	O	O	O	O	O
SIRIUSXM [®] SATELLITE RADIO [™] (included in Tradesman Popular Equipment Group)	P	P	S	S	S	S	S	S	S	S
SIRIUSXM TRAFFIC [™] AND SIRIUSXM TRAVEL LINK [™] (included with Uconnect 8.4 NAV system)	—	—	—	P	P	P	P	P	S	S
SPEAKER SYSTEMS — Six speakers	S	S	S	S	S	S	—	—	—	—
— Six premium speakers (Regular Cab only)	—	—	O	—	—	—	—	—	—	—
— Nine amplified speakers with subwoofer (Surround Sound requires ADA and *M9 or higher seat)	—	—	O	O	O	O	S	S	S	S
UCONNECT VOICE COMMAND WITH BLUETOOTH [™] (included with Uconnect 5.0, 8.4 and 8.4 NAV systems)	P	P	S	S	S	S	S	S	S	S
TIRES AND WHEELS										
TIRES — 2500 LT245/70R17E BSW All-Season tires	S	—	—	—	—	—	—	—	—	—
— LT285/70R17D OWL All-Terrain tires	—	S	—	—	—	S	—	S	—	—
— LT275/70R18E BSW All-Season tires (included with Chrome Appearance Group)	P	—	S	S	—	—	S	—	S	—
— LT275/70R18E OWL On-/Off-Road tires (included with Snow Chief [®] Group and Popular Equipment Group; optional with Chrome Appearance Group)	O	—	P/O	O	S	—	O	—	O	—
— LT285/60R20E OWL On-/Off-Road tires (included with optional 20-inch wheels)	—	—	P	P	P	—	P	—	P	S
— Full-size spare tire	S	S	S	S	S	S	S	S	S	S
— Add full-size spare tire (requires Box Delete)	O	—	O	O	—	—	—	—	—	—
3500 SINGLE REAR WHEEL — LT275/70R18E BSW All-Season tires	S	—	S	S	—	—	S	—	S	—
— LT275/70R18E OWL On-/Off-Road tires (included with Snow Chief Group and Popular Equipment Group; optional with Chrome Appearance Group)	O	—	P/O	O	—	—	O	—	O	—
— LT285/60R20E OWL On-/Off-Road tires (included with optional 20-inch wheels)	—	—	O	O	—	—	O	—	O	S
3500 DUAL REAR WHEEL — LT235/80R17E BSW All-Season tires	S	—	S	S	—	—	S	—	S	S
— LT235/80R17E OWL On-/Off-Road tires (included with Popular Equipment Group)	O	—	O/P	O	—	—	O	—	O	O
WHEELS — 2500 — 17 x 7.5-inch steel painted	S	—	—	—	—	—	—	—	—	—
— 17 x 8-inch polished forged aluminum	—	S	—	—	—	S	—	S	—	—
— 18 x 8-inch steel painted	O	—	—	—	—	—	—	—	—	—
— 18 x 8-inch steel chrome-clad (included with Chrome Appearance Group)	P	—	S	—	—	—	—	—	—	—
— 18 x 8-inch polished aluminum	—	—	O	S	S	—	—	—	—	—
— 18 x 8-inch polished aluminum	—	—	—	—	—	—	S	—	—	—
— 18 x 8-inch polished aluminum with White Gold pockets	—	—	—	—	—	—	—	—	S	—
— 18 x 8-inch polished aluminum with Silver pockets (included with Monotone paint)	—	—	—	—	—	—	—	—	P	—
— 20 x 8-inch aluminum painted Black (included with Black Appearance Group)	—	—	—	P	—	—	P	—	—	—
— 20 x 8-inch aluminum painted Satin Carbon with chrome inserts	—	—	O	O	O	—	O	—	—	—
— 20 x 8-inch polished aluminum with White Gold pockets	—	—	—	—	—	—	—	—	O	—
— 20 x 8-inch polished aluminum with Silver pockets (optional with Monotone paint)	—	—	—	—	—	—	—	—	O	—
— 20 x 8-inch aluminum premium painted with chrome inserts	—	—	—	—	—	—	—	—	—	S
— Steel spare	S	S	S	S	S	S	S	S	S	S
3500 SINGLE REAR WHEEL — 18 x 8-inch steel painted	S	—	—	—	—	—	—	—	—	—
— 18 x 8-inch steel chrome-clad (included in Chrome Appearance Group)	P	—	S	—	—	—	—	—	—	—
— 18 x 8-inch polished aluminum	—	—	O	S	—	—	—	—	—	—
— 18 x 8-inch polished aluminum	—	—	—	—	—	—	S	—	—	—
— 18 x 8-inch polished aluminum with White Gold pockets	—	—	—	—	—	—	—	—	S	—
— 18 x 8-inch polished aluminum with Silver pockets (included with Monotone paint)	—	—	—	—	—	—	—	—	P	—
— 20 x 8-inch aluminum painted Black (included with Black Appearance Group)	—	—	—	P	—	—	P	—	—	—
— 20 x 8-inch aluminum painted Satin Carbon with chrome inserts	—	—	O	O	—	—	O	—	—	—
— 20 x 8-inch polished aluminum with White Gold pockets	—	—	—	—	—	—	—	—	O	—
— 20 x 8-inch polished aluminum with Silver pockets (optional with Monotone paint)	—	—	—	—	—	—	—	—	O	—
— 20 x 8-inch aluminum premium painted with chrome inserts	—	—	—	—	—	—	—	—	—	S
— Steel spare	S	—	S	S	—	—	S	—	S	S

S = Standard, O = Optional, P = Part of Package, — = Not available.
 Note: some features and/or applications may be late availability.

¹Lone Star model available only in Texas.

RAM 2500/3500 BUYER'S GUIDE

	TRADESMAN® REG./CREW	TRADESMAN POWER WAGON® CREW	SLT REG./CREW/MEGA	BIGHORN®/LONE STAR® CREW/MEGA	OUTDOORSMAN® CREW	POWER WAGON CREW	LARAMIE® CREW/MEGA	LARAMIE POWER WAGON CREW	LARAMIE LONGHORN® CREW/MEGA	LIMITED CREW/MEGA
	2TA	2TB	2TG	2TZ/2TY	2TT	2TP	2TH	2TJ	2TK	2TM
CPOS PACKAGE										
TIRES AND WHEELS (continued)										
3500 DUAL REAR WHEEL — 17 x 6-inch steel painted	\$	—	—	—	—	—	—	—	—	—
— 17 x 6-inch steel with chrome finish (included in Chrome Appearance Group)	P	—	\$	\$	—	—	—	—	—	—
— 17 x 6-inch polished aluminum	—	—	0	0	—	—	\$	—	—	\$
— 17 x 6-inch polished aluminum with Laramie Longhorn cap	—	—	—	—	—	—	—	—	\$	—
— 17-inch steel spare (included with DRW models)	\$	—	\$	\$	—	—	\$	—	\$	\$
SAFETY AND SECURITY										
AIR BAGS ⁽¹⁾ — Multistage front and knee bolsters	\$	\$	\$	\$	\$	\$	\$	\$	\$	\$
— Supplemental side-curtain	\$	\$	\$	\$	\$	\$	\$	\$	\$	\$
— Supplemental front-seat side-mounted	\$	\$	\$	\$	\$	\$	\$	\$	\$	\$
BRAKES — Four-wheel antilock disc brakes	\$	\$	\$	\$	\$	\$	\$	\$	\$	\$
CARGO-VIEW CAMERA ⁽²⁾ (requires Uconnect® 8.4 or 8.4 NAV systems)	—	—	0	0	0	0	0	0	0	0
ELECTRONIC STABILITY CONTROL ⁽³⁾ — Includes All-Speed Traction Control, Brake Assist, Electronic Roll Mitigation, Hill Start Assist, Rain Brake Support, Ready Alert Braking and Trailer Sway Damping ⁽⁴⁾	\$	\$	\$	\$	\$	\$	\$	\$	\$	\$
ELECTRONIC TRAILER BRAKE CONTROLLER	0	0	\$	\$	\$	\$	\$	\$	\$	\$
KEY ALIKE (3500 only; not available with Keyless Enter 'n Go™)	0	0	0	0	0	0	0	0	0	0
PARKSENSE® FRONT AND REAR PARK ASSIST ⁽²⁾	—	—	0	0	0	0	\$	\$	\$	\$
PARKSENSE REAR PARK ASSIST ⁽²⁾	0	0	0	0	0	0	—	—	—	—
PARKVIEW® REAR BACK-UP CAMERA ⁽²⁾ — Video displayed in rearview mirror with Radio 3.0 or on-screen with Cargo-View Camera ⁽²⁾ with other systems	0	0	0	0	0	0	\$	\$	\$	\$
REMOTE KEYLESS ENTRY WITH ALLSECURE® — Controls for power door locks, tailgate, RamBox® System, illuminated entry system, panic alarm (included in Tradesman Popular Equipment Group or Power and Remote Entry Group)	P	P	\$	\$	\$	\$	\$	\$	\$	\$
REMOTE START — Requires automatic transmission	—	—	0	\$	\$	0	0	0	\$	\$
SECURITY ALARM — Detects break-in	—	—	0	0	\$	0	\$	\$	\$	\$
SENTRY KEY® THEFT DETERRENT SYSTEM — Engine immobilizer	\$	\$	\$	\$	\$	\$	\$	\$	\$	\$
TIRE PRESSURE MONITORING (TPM) within Driver Information Display and alert (2500 only)	\$	\$	\$	\$	\$	\$	\$	\$	\$	\$
TIRE PRESSURE INFORMATION SYSTEM without alert (3500 models only)	\$	—	\$	\$	—	—	\$	—	\$	\$
PACKAGES / EQUIPMENT GROUPS										
BLACK APPEARANCE GROUP — Includes Black door handles, Black exterior mirrors, Black Ram tailgate badge, Black 4x4 badge (4x4 only), black-out headlamps, Black painted front and rear bumpers, Black grille and 20-inch Black painted wheels with OWL tires (SRW Models only)	—	—	—	0	—	—	—	—	—	—
BOX DELETE — Regular Cab, Crew Cab, with 5.7L gas engine	0	—	0	0	—	—	—	—	—	—
CHROME APPEARANCE GROUP — Includes chrome bumpers, chrome grille surround and steel chrome-clad wheels (SRW) or steel wheels with chrome finish (DRW)	0	—	—	—	—	—	—	—	—	—
COLD WEATHER GROUP — Includes engine block heater and winter front grille cover (diesel only)	0	—	0	0	0	—	0	—	0	0
HEATED SEATS AND STEERING WHEEL GROUP — Includes heated cloth seats, heated leather steering wheel and if equipped with Uconnect 8.4 or 8.4 NAV systems, Dual-Zone ATC (requires *M9 or *MJ seats; included with Luxury Group)	—	—	—	0/P	0	0	—	—	—	—
CONVENIENCE GROUP — Includes Auto High-Beam Headlamp Control, rain-sensitive wipers (not available with Cargo-View Camera ⁽²⁾)	—	—	—	—	—	—	0	0	0	—
DOT-CERTIFIED ROADSIDE SAFETY KIT — Includes DOT fire extinguisher, three reflecting triangles, two Red vinyl flags and spare fuses	0	0	0	0	0	0	0	0	0	0
DUAL REAR WHEEL GROUP — 3500 only; N/A with Crew Cab 6'4" box (includes clearance lamps for the cab, box and fenders)	0	—	0	0	—	—	0	—	0	0
FIFTH-WHEEL/GOOSENECK TOWING PREP GROUP — Includes in-bed 7-pin harness connector and mounting provisions for 5th-wheel or gooseneck hitches	0	—	0	0	0	—	0	—	0	0
CHROME BUMPER PACKAGE — Includes chrome front and rear bumpers	—	—	—	—	—	—	—	—	—	0
LUXURY GROUP — Includes 7-inch Driver Information Display, switchable dome lamp, ashtray lamp, illuminated vanity mirror, auto day/night mirror, LED Bed Lighting, exterior power folding mirrors with signal and puddle lamps, overhead console with Universal Garage Door Opener and if equipped with 8.4 inch radio, Dual-Zone ATC; for 2TG/2TP only; leather-wrapped steering wheel with audio controls, glove box lamp, under-hood lamp; for 2TY/2TZ only: Comfort Group	—	—	0	0	\$	0	—	—	—	—
POPULAR EQUIPMENT GROUP TRADESMAN — Includes 40/20/40 cloth bench seat, carpeted floor covering, floor mats, remote keyless entry and SiriusXM® Satellite Radio ⁽⁴⁾	0	0	—	—	—	—	—	—	—	—
POPULAR EQUIPMENT GROUP SLT — Includes premium cloth 40/20/40 bench seat, fog lamps, OWL tires (Regular Cab only)	—	—	0	—	—	—	—	—	—	—
POWER AND REMOTE ENTRY GROUP — Includes premium vinyl door trim, remote keyless entry, power heated mirror, power windows and power locks (Regular Cab only)	0	—	—	—	—	—	—	—	—	—
PROTECTION GROUP (4x4 ONLY) — Includes tow hooks and transfer case skid plate	0	—	0	0	\$	—	0	—	0	0
SMOKER'S GROUP — Includes removable ashtray and cigar lighter	0	0	0	0	0	0	0	0	0	0
SNOW CHIEF® GROUP — Includes 180-amp alternator for 5.7L V8, (220-amp alternator for 6.4L V8 or 6.7L Cummins® Turbo Diesel), antispin differential, transfer case skid plate, auxiliary switches, clearance lamps, 18-inch wheels and OWL On-/Off-Road tires (single-rear-wheel models only)	0	—	0	0	0	—	0	—	0	0
SNOWPLOW PREP GROUP — Includes 180-amp alternator (gas), 220-amp (diesel), transfer case skid plate (4x4 models only)	0	—	0	0	0	—	0	—	0	0
SPORT APPEARANCE GROUP — Includes monotone paint, body-color door handles, Black exterior mirrors, Black Ram tailgate badge, Black 4x4 badge (4x4 only), black-out projector headlamps and black-out LED taillamps, body-color painted front and rear bumpers, body-color grille with Black insert and 20-inch Black painted wheels with OWL tires (SRW models only)	—	—	—	—	—	—	0	—	—	—

S = Standard. 0 = Optional. P = Part of Package. — = Not available.
 Note: some features and/or applications may be late availability.

¹Lone Star model available only in Texas.



CUSTOM-MINDED.

Ram 3500 Regular Cab Tradesman® in Bright White shown with Mopar® Chrome Tubular Side Steps and Gooseneck Trailer Hitch. Properly secure all cargo.

MOPAR. SUPPORTING YOU AND YOUR RAM TRUCK—FOR THE LONG HAUL.

Here's how to make your new Ram truck the ideal ride... for today, and for many years to come. It's through Mopar.

Authentic Parts and Accessories by Mopar are engineered by the same experts who designed your Ram truck. Fit, function and finish are perfect, and the trained technicians who service your pickup know your make and model inside out. With genuine parts and this level of knowledge, you're going to keep your Ram truck going strong and looking good.

Further Mopar advantages include Mopar Express Lane Service to minimize waiting and downtime; Mopar Vehicle Protection® Plans—the only extended protection backed by the manufacturer; and our state-of-the-art Mopar Owner Connect Web site. This gives you online access to your service records, vehicle information, and exclusive money-saving offers. Mopar. It's about keeping you happy, and your Ram truck at its best. Get it all at MOPAR.COM



Ladder Rack, in Aluminum or Steel



Heavy-Duty Commercial Toolbox



Direct-Mount Fifth-Wheel Hitch*



Heavy-Duty Splash Guards

*Check User Guide for hitch type, load capacity and heavy-duty equipment required. Do not exceed rated tow capacity of the vehicle as equipped. Trailer may require items not supplied by Mopar.



[1] Based on latest available competitive information. Class based on 250/2500 and 350/3500 pickups. [2] Always look before proceeding, electronic drive aid is not a substitute for conscientious driving; always be aware of your surroundings. [3] Based on latest available competitive information. Class based on all full-size pickups. [4] SiriusXM subscriptions for audio and data services are sold by SiriusXM to follow your trial subscription. **If you decide to continue listening after your trial, the subscription plan you choose will automatically renew thereafter and you will be charged according to your chosen payment method at then-current rates.** Fees and taxes apply. To cancel, you must call SiriusXM at 1-866-635-2349. See the SiriusXM Customer Agreement for complete terms and more information at siriusxm.com. All fees and programming subject to change. Your equipment and features for SiriusXM services will vary depending upon the vehicle you select and may be limited in select markets. [5] Vehicle must be within the United States, have network coverage and must be registered with Uconnect Access with an active subscription that includes the applicable feature and you must fulfill minimum subscription requirements. It must also be equipped with features that enable remote commands, such as keyless entry, and must be in active and usable cellular range. The Uconnect Access App must be installed and launched on your mobile device to use these remote commands. Remote features are available only on vehicles that are properly equipped. Check state and local laws regarding the use of remote start systems. [6] Voice Text Reply and Voice Texting features require a compatible mobile device enabled with Bluetooth Message Access Profile (MAP). iPhone and some other smartphones do not currently support Bluetooth MAP. Visit UconnectPhone.com for system and device compatibility. Ensure MAP is ON and incoming message notification is enabled. Vehicle must be registered for Uconnect Access and you must fulfill minimum subscription requirements. Also requires the use of a compatible smartphone that supports text messaging and Bluetooth. Visit UconnectPhone.com for system and device compatibility. [7] Requires a mobile phone equipped with the Bluetooth Hands-Free Profile. Visit UconnectPhone.com for system and device compatibility. [8] The 9-1-1 Call button will connect you directly with Emergency Assistance. If you accidentally press the button, you have 10 seconds to cancel the call by either pressing the 9-1-1 button on the rearview mirror or the Cancel button on the Uconnect touchscreen. [9] Provides direct-dial access to Roadside Assistance Service. Vehicle must be within the United States, have network coverage and must be registered with Uconnect Access with an active subscription that includes the applicable feature. Additional roadside assistance charges may apply. Check warranty for details. [10] WiFi subscription required. Vehicle must be registered with Uconnect Access and fulfill minimum subscription requirements. Vehicle must be properly equipped and in active and usable cellular range for WiFi usage. WiFi Hotspot does not enable direct communication between multiple in-vehicle devices. Factors affecting the performance of WiFi Hotspot include: cellular network, signal strength and quality, time of day, number of channels used by the service provider, type of connection, number of clients using WiFi Hotspot and client device. This feature is not intended for use by the driver while the vehicle is in motion. Always drive safely. [11] The Advanced Front Air Bags in this vehicle are certified to the new U.S. Federal regulations for advanced air bags. Children 12 years old and younger should always ride buckled up in a rear seat. Infants in rear-facing child restraints should never ride in the front seat of a vehicle with a passenger front air bag. All occupants should always wear their lap and shoulder belts properly. [12] No system, no matter how sophisticated, can repeal the laws of physics or overcome careless driving actions. Performance is limited by available traction, which snow, ice and other conditions can affect. When the ESC warning lamp flashes, the driver needs to use less throttle and adapt speed and driving behavior to prevailing road conditions. Always drive carefully, consistent with conditions. Always wear your seat belt.

©2015 FCA US LLC. All Rights Reserved. Chrysler, Ram, Mopar, Active Air, AllSecure, Big Horn, HEMI, Laramie, Laramie Longhorn, Mega Cab, the Mopar Owner Connect design, Mopar Vehicle Protection, Outdoorsman, ParkSense, ParkView, Power Wagon, RamBox, the Ram's Head logo, Sentry Key, Snow Chief, Tradesman, Tru-Lok and Uconnect are registered trademarks, and Active-Level, Keyless Enter 'n Go and Ram Work Grade are trademarks of FCA US LLC.

Cummins is a registered trademark of Cummins, Inc. AISIN is a registered trademark of Aisin Seiki Co., Ltd. Goodyear, Wrangler and DuraTrac are registered trademarks of The Goodyear Tire & Rubber Company. Bilstein is a registered trademark of August-Bilstein GmbH & Co. WARN is a registered trademark of Warn Industries, Inc. iPhone is a registered trademark of Apple Inc. Bluetooth is a registered trademark of Bluetooth SIG, Inc. Sirius, XM and all related marks and logos are trademarks of SiriusXM Radio Inc. Facebook and logo are registered trademarks of Facebook, Inc. The Twitter logo is a service mark of Twitter, Inc. The YouTube logo is a registered trademark of Google Inc. Yelp is a registered trademark of Yelp. Instagram and logo are registered trademarks of Instagram, Inc.

About this catalog: Since the time of printing, some of the information you'll find in this catalog may have been updated. Ask your dealer for details. Some of the equipment shown or described throughout this catalog may be available at extra cost. Specifications, descriptions, illustrative materials and all competitive comparisons contained herein are as accurate as known at the time this publication was approved for printing. FCA US LLC reserves the right to discontinue models at any time or change specifications without notice or without incurring obligation. Options may be required in combination with other options. For the price of the model with the equipment you desire, or verification of specifications contained here, see your Ram dealer.



Join our community on Facebook, submit your photos on Instagram, follow us on Twitter and check us out on YouTube.



Join fellow Ram enthusiasts and tell your story by posting comments, participating in discussions and sharing your photos and videos

THE RAM OUTFITTER

Owning a new 2016 Ram Heavy Duty opens up a world of new apparel, tools and a variety of equipment for work and play. The one place to find it all is the Ram Outfitter site.

This is the online shopping center for gear and gifts for the Ram enthusiast. With the Ram identity prominently featured, you can choose from authentic wear, sports equipment, electronics and attire.

RAMTRUCKS.COM/OUTFITTER



RAMTRUCKS.COM

Ram is a registered trademark of FCA US LLC.